

# GRAVITY CALCULATIONS

## RANKIN RESIDENCE

### DESIGN LOADS

#### FLOOR:

LIVE: 40 PSF  
DEAD: 10 PSF

#### ROOF:

LIVE: 25 PSF  
DEAD: 15 PSF

#### DECK:

LIVE: 60PSF  
DEAD: 10 PSF

#### SOIL BEARING:

1500 PSF



#### PREPARED BY:

J3 ARCHITECTS LLC

206-412-9296

03-03-25

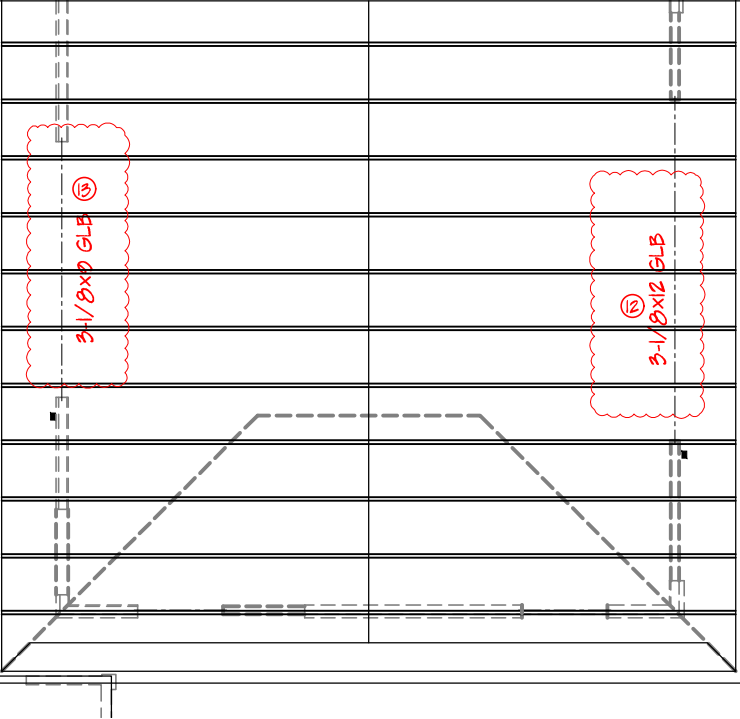
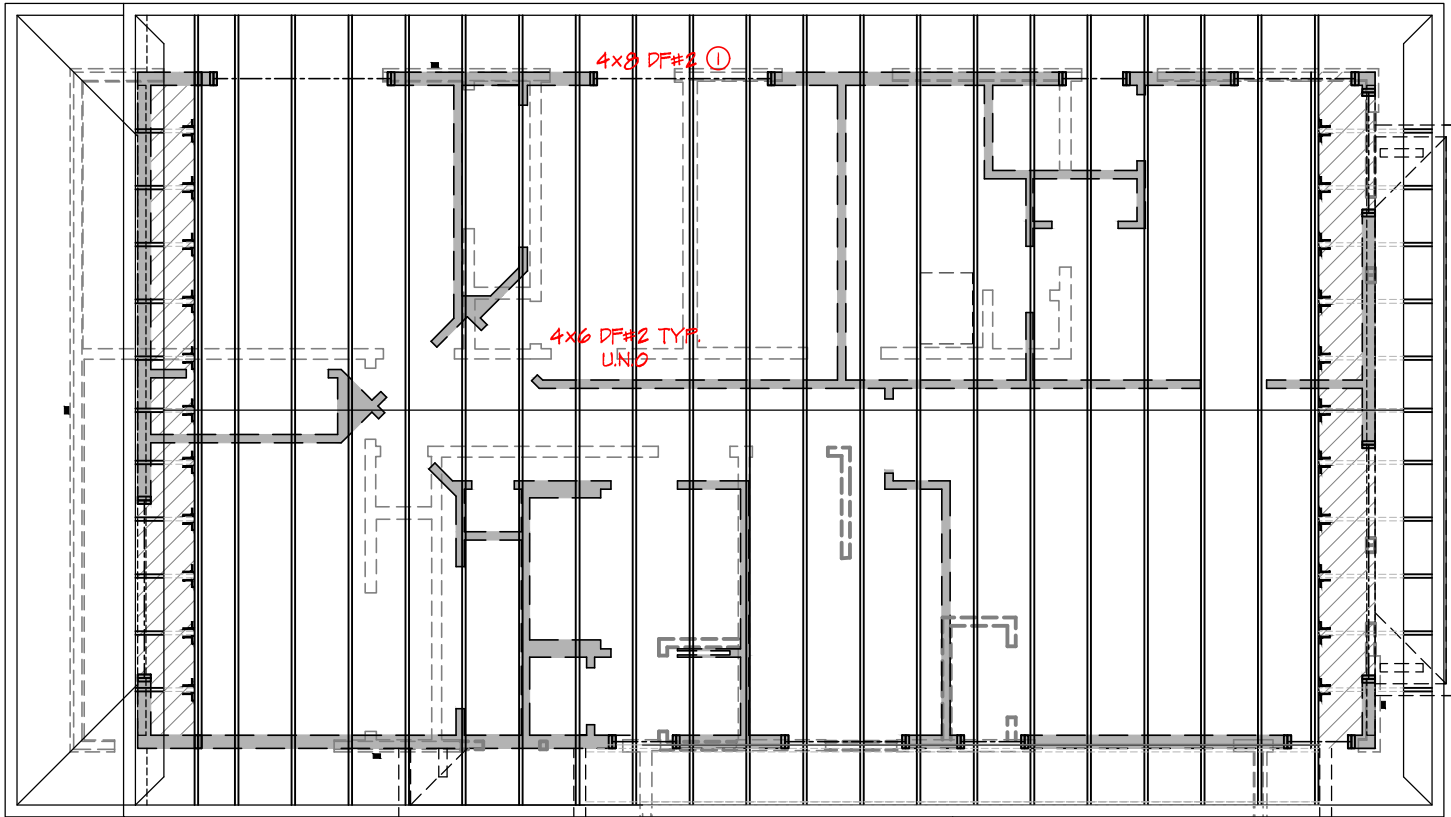



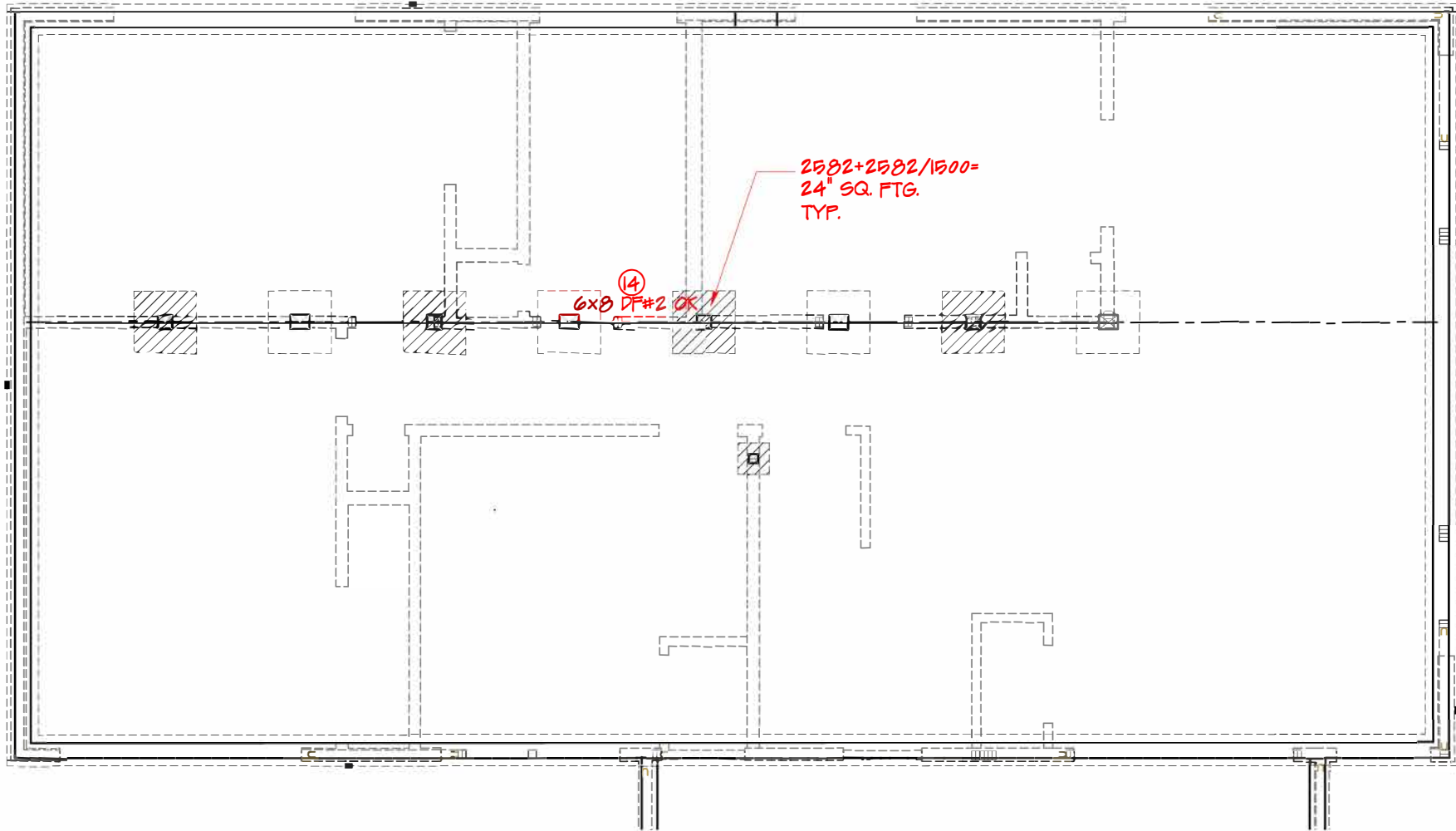

14  
6x8 DF#2 OK

2582+2582/1500=  
24" SQ. FTG.  
TYP.

RANKIN

BDRM 2 WIN

Date: 11/08/24

Selection      **4x 8 DF-L #2**      Lu = 0.0 Ft

Conditions      NDS 2018

Data      Min Bearing Area      R1= 2.8 in<sup>2</sup>      R2= 2.8 in<sup>2</sup>      (1.5) DL Defl= 0.06 in

Beam Span	6.25 ft	Reaction 1 LL	1087 #	Reaction 2 LL	1087 #
Beam Wt per ft	6.17 #	Reaction 1 TL	1758 #	Reaction 2 TL	1758 #
Bm Wt Included	39 #	Maximum V	1758 #		
Max Moment	2747 #'	Max V (Reduced)	1418 #		
TL Max Defl	L / 240	TL Actual Defl	L / 581		
LL Max Defl	L / 360	LL Actual Defl	L / >1000		

<u>Attributes</u>	Section (in <sup>3</sup> )	Shear (in <sup>2</sup> )	TL Defl (in)	LL Defl
Actual	30.66	25.38	0.13	0.07
Critical	28.17	11.82	0.31	0.21
Status	OK	OK	OK	OK
Ratio	92%	47%	41%	32%

<u>Values</u>	Fb (psi)	Fv (psi)	E (psi x mil)	Fc <sub>⊥</sub> (psi)
Reference Values	900	180	1.6	625
Adjusted Values	1170	180	1.6	625

<u>Adjustments</u>	CF Size Factor	Cd Duration	Cr Repetitive	Ch Shear Stress	Cm Wet Use	CI Stability
	1.300	1.00	1.00	N/A	1.00	1.0000
						Rb = 0.00      Le = 0.00 Ft

Loads      Uniform LL: 348      Uniform TL: 556 = A

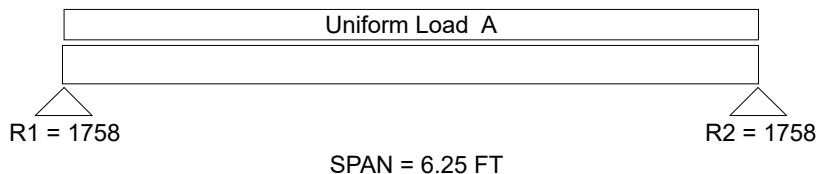

Uniform and partial uniform loads are lbs per lineal ft.

RANKIN

GREAT RM RIDGE

Date: 11/08/24

Selection **5-1/8x 18 GLB 24F-V4 DF/DF** Lu = 0.0 Ft

Conditions NDS 2018

Min Bearing Area R1= 8.6 in<sup>2</sup> R2= 8.6 in<sup>2</sup> (1.5) DL Defl= 0.49 in Recom Camber= 0.73 in

Data

Beam Span	24.3 ft	Reaction 1 LL	3311 #	Reaction 2 LL	3311 #
Beam Wt per ft	22.42 #	Reaction 1 TL	5570 #	Reaction 2 TL	5570 #
Bm Wt Included	545 #	Maximum V	5570 #		
Max Moment	33836 #	Max V (Reduced)	4882 #		
TL Max Defl	L / 240	TL Actual Defl	L / 303		
LL Max Defl	L / 360	LL Actual Defl	L / 613		

Attributes

	Section (in <sup>3</sup> )	Shear (in <sup>2</sup> )	TL Defl (in)	LL Defl
Actual	276.75	92.25	0.96	0.48
Critical	178.77	30.51	1.22	0.81
Status	OK	OK	OK	OK
Ratio	65%	33%	79%	59%

Values

	Fb (psi)	Fv (psi)	E (psi x mil)	Fc <sub>I</sub> (psi)
Reference Values	2400	240	1.8	650
Adjusted Values	2271	240	1.8	650

Adjustments

Cv Volume	0.946			
Cd Duration	1.00	1.00		
Cr Repetitive	1.00			
Ch Shear Stress		N/A		
Cm Wet Use	1.00	1.00	1.00	1.00
CI Stability	1.0000	Rb = 0.00	Le = 0.00 Ft	

Loads

Uniform LL: 273

Uniform TL: 436 = A

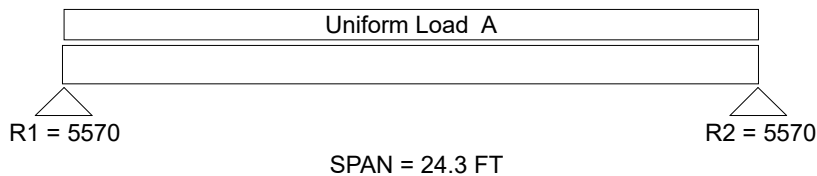

Uniform and partial uniform loads are lbs per lineal ft.

RANKIN  
RAFTERS

Date: 11/08/24

Selection (2) 2x 6 HF #2 @ 19.2 in oc Lu = 0.0 Ft

Conditions NDS 2018, Repetitive Use

Min Bearing Area R1= 0.9 in<sup>2</sup> R2= 0.9 in<sup>2</sup> (1.5) DL Defl= 0.21 in

Data

Beam Span	10.9 ft	Reaction 1 LL	218 #	Reaction 2 LL	218 #
Beam Wt per ft	0 #	Reaction 1 TL	349 #	Reaction 2 TL	349 #
Bm Wt Included	0 #	Maximum V	349 #		
Max Moment	950 #	Max V (Reduced)	319 #		
TL Max Defl	L / 240	TL Actual Defl	L / 293		
LL Max Defl	L / 360	LL Actual Defl	L / 558		

Attributes

	Section (in <sup>3</sup> )	Shear (in <sup>2</sup> )	TL Defl (in)	LL Defl
Actual	15.13	16.50	0.45	0.23
Critical	8.98	3.19	0.55	0.36
Status	OK	OK	OK	OK
Ratio	59%	19%	82%	65%

Values

	Fb (psi)	Fv (psi)	E (psi x mil)	Fc <sub>I</sub> (psi)
Reference Values	850	150	1.3	405
Adjusted Values	1271	150	1.3	405

Adjustments

CF Size Factor	1.300			
Cd Duration	1.00	1.00		
Cr Repetitive	1.15			
Ch Shear Stress		N/A		
Cm Wet Use	1.00	1.00	1.00	1.00
CI Stability	1.0000	Rb = 0.00	Le = 0.00 Ft	

Loads

Uniform LL: 40

Uniform TL: 64 = A

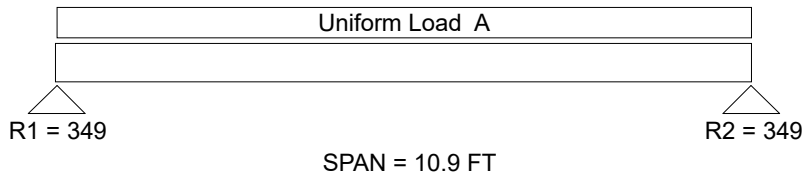

Uniform and partial uniform loads are lbs per lineal ft.



RANKIN

UFF BM

Date: 11/08/24

Selection

**5-1/8x 9 GLB 24F-V4 DF/DF**

Lu = 0.0 Ft

Conditions

NDS 2018

Min Bearing Area R1= 4.9 in<sup>2</sup> R2= 4.9 in<sup>2</sup> (1.5) DL Defl= 0.10 in Recom Camber= 0.14 in

Data

Beam Span	10.5 ft	Reaction 1 LL	2501 #	Reaction 2 LL	2501 #
Beam Wt per ft	11.21 #	Reaction 1 TL	3185 #	Reaction 2 TL	3185 #
Bm Wt Included	118 #	Maximum V	3185 #		
Max Moment	8361 #	Max V (Reduced)	2730 #		
TL Max Defl	L / 240	TL Actual Defl	L / 385		
LL Max Defl	L / 360	LL Actual Defl	L / 543		

Attributes

	Section (in <sup>3</sup> )	Shear (in <sup>2</sup> )	TL Defl (in)	LL Defl
Actual	69.19	46.13	0.33	0.23
Critical	41.81	17.06	0.53	0.35
Status	OK	OK	OK	OK
Ratio	60%	37%	62%	66%

Values

	Fb (psi)	Fv (psi)	E (psi x mil)	Fc <sub>I</sub> (psi)
Reference Values	2400	240	1.8	650
Adjusted Values	2400	240	1.8	650

Adjustments

Cv Volume	1.000			
Cd Duration	1.00	1.00		
Cr Repetitive	1.00			
Ch Shear Stress		N/A		
Cm Wet Use	1.00	1.00	1.00	1.00
CI Stability	1.0000	Rb = 0.00	Le = 0.00 Ft	

Loads

Uniform LL: 476

Uniform TL: 596 = A

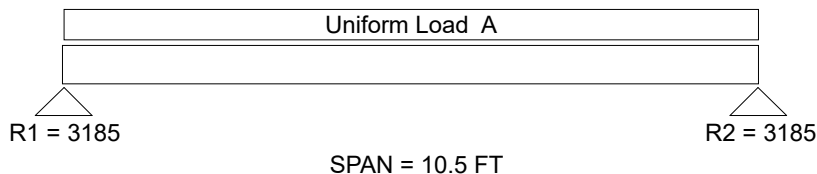

Uniform and partial uniform loads are lbs per lineal ft.

RANKIN

UFF- DBL JST **USE 2-2x10 HF#2**

Date: 11/13/24

Selection **2x 10 HF #2** Lu = 0.0 Ft

Conditions NDS 2018

Min Bearing Area R1= 2.1 in<sup>2</sup> R2= 2.1 in<sup>2</sup> (1.5) DL Defl= <0.01 in.

Data

Beam Span	2.8 ft	Reaction 1 LL	666 #	Reaction 2 LL	666 #
Beam Wt per ft	3.37 #	Reaction 1 TL	839 #	Reaction 2 TL	839 #
Bm Wt Included	9 #	Maximum V	839 #		
Max Moment	587 '#	Max V (Reduced)	377 #		
TL Max Defl	L / 240	TL Actual Defl	L / >1000		
LL Max Defl	L / 360	LL Actual Defl	L / >1000		

Attributes

	Section (in <sup>3</sup> )	Shear (in <sup>2</sup> )	TL Defl (in)	LL Defl
Actual	21.39	13.88	0.01	<0.01
Critical	7.54	3.77	0.14	0.09
Status	OK	OK	OK	OK
Ratio	35%	27%	5%	5%

Values

	Fb (psi)	Fv (psi)	E (psi x mil)	Fc <sub>I</sub> (psi)
Reference Values	850	150	1.3	405
Adjusted Values	935	150	1.3	405

Adjustments

CF Size Factor	1.100			
Cd Duration	1.00	1.00		
Cr Repetitive	1.00			
Ch Shear Stress		N/A		
Cm Wet Use	1.00	1.00	1.00	1.00
CI Stability	1.0000	Rb = 0.00	Le = 0.00 Ft	

Loads

Uniform LL: 476

Uniform TL: 596 = A

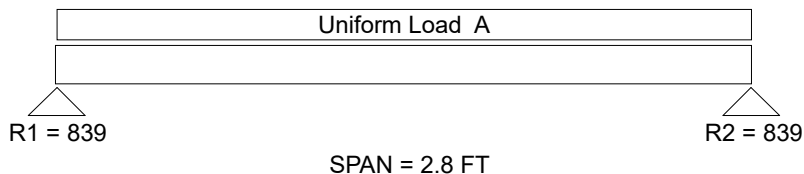

Uniform and partial uniform loads are lbs per lineal ft.

RANKIN

DINING WIN

Date: 11/08/24

Selection **3-1/8x 10-1/2 GLB 24F-V4 DF/DF** Lu = 0.0 Ft

Conditions NDS 2018

Min Bearing Area R1= 3.1 in<sup>2</sup> R2= 5.2 in<sup>2</sup> (1.5) DL Defl= 0.08 in Recom Camber= 0.13 in

Data

Beam Span	9.25 ft	Reaction 1 LL	1406 #	Reaction 2 LL	2506 #
Beam Wt per ft	7.97 #	Reaction 1 TL	1992 #	Reaction 2 TL	3394 #
Bm Wt Included	74 #	Maximum V	3394 #		
Max Moment	8008 #	Max V (Reduced)	3186 #		
TL Max Defl	L / 240	TL Actual Defl	L / 469		
LL Max Defl	L / 360	LL Actual Defl	L / 725		

Attributes

	Section (in <sup>3</sup> )	Shear (in <sup>2</sup> )	TL Defl (in)	LL Defl
Actual	57.42	32.81	0.24	0.15
Critical	40.04	19.91	0.46	0.31
Status	OK	OK	OK	OK
Ratio	70%	61%	51%	50%

Values

	Fb (psi)	Fv (psi)	E (psi x mil)	Fc <sub>I</sub> (psi)
Reference Values	2400	240	1.8	650
Adjusted Values	2400	240	1.8	650

Adjustments

Cv Volume	1.000			
Cd Duration	1.00	1.00		
Cr Repetitive	1.00			
Ch Shear Stress		N/A		
Cm Wet Use	1.00	1.00	1.00	1.00
CI Stability	1.0000	Rb = 0.00	Le = 0.00 Ft	

Loads

		Uniform LL: 40		Uniform TL: 50 = A		
Point LL	Point TL	Distance	Par Unif LL	Par Unif TL	Start	End
2501	B = 3185	6.66	75	H = 120	0	9.25
			38	I = 60	0	9.25

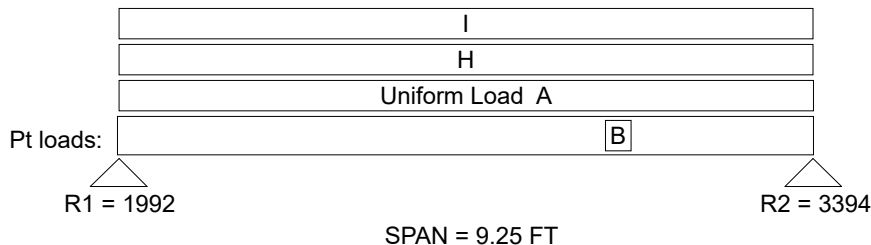

Uniform and partial uniform loads are lbs per lineal ft.

RANKIN  
ENTRY DR

Date: 11/13/24

Selection (2) 1-3/4x 9-1/4 1.9E TJ Microllam LVL Lu = 0.0 Ft

Conditions NDS 2018

Min Bearing Area R1= 5.2 in<sup>2</sup> R2= 4.5 in<sup>2</sup> (1.5) DL Defl= 0.04 in

Data

Beam Span	6.2 ft	Reaction 1 LL	2817 #	Reaction 2 LL	2484 #
Beam Wt per ft	8.32 #	Reaction 1 TL	3930 #	Reaction 2 TL	3399 #
Bm Wt Included	52 #	Maximum V	3930 #		
Max Moment	6128 #	Max V (Reduced)	2959 #		
TL Max Defl	L / 240	TL Actual Defl	L / 667		
LL Max Defl	L / 360	LL Actual Defl	L / >1000		

Attributes

	Section (in <sup>3</sup> )	Shear (in <sup>2</sup> )	TL Defl (in)	LL Defl
Actual	49.91	32.38	0.11	0.07
Critical	27.30	15.57	0.31	0.21
Status	OK	OK	OK	OK
Ratio	55%	48%	36%	34%

Values

	Fb (psi)	Fv (psi)	E (psi x mil)	Fc <sub>I</sub> (psi)
Reference Values	2600	285	1.9	750
Adjusted Values	2694	285	1.9	750

Adjustments

CF Size Factor	1.036			
Cd Duration	1.00	1.00		
Cr Repetitive	1.00			
Ch Shear Stress		N/A		
Cm Wet Use	1.00	1.00	1.00	1.00
CI Stability	1.0000	Rb = 0.00	Le = 0.00 Ft	

Loads

Point LL	Point TL	Distance	Par Unif LL	Par Unif TL	Start	End
391	B = 629	4.2	348	H = 556	0	4.2

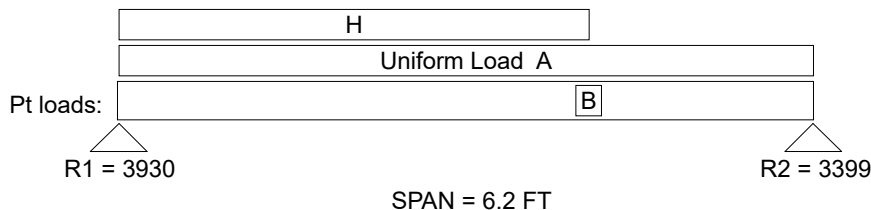

Uniform and partial uniform loads are lbs per lineal ft.

RANKIN

DINING ENTRY OPEN

Date: 11/08/24

Selection **3-1/8x 9 GLB 24F-V4 DF/DF** Lu = 0.0 Ft

Conditions NDS 2018

Min Bearing Area R1= 5.1 in<sup>2</sup> R2= 5.1 in<sup>2</sup> (1.5) DL Defl= 0.08 in Recom Camber= 0.12 in

Data

Beam Span	7.25 ft	Reaction 1 LL	2261 #	Reaction 2 LL	2261 #
Beam Wt per ft	6.83 #	Reaction 1 TL	3292 #	Reaction 2 TL	3292 #
Bm Wt Included	50 #	Maximum V	3292 #		
Max Moment	5967 #'	Max V (Reduced)	2611 #		
TL Max Defl	L / 240	TL Actual Defl	L / 440		
LL Max Defl	L / 360	LL Actual Defl	L / 744		

Attributes

	Section (in <sup>3</sup> )	Shear (in <sup>2</sup> )	TL Defl (in)	LL Defl
Actual	42.19	28.13	0.20	0.12
Critical	29.84	16.32	0.36	0.24
Status	OK	OK	OK	OK
Ratio	71%	58%	55%	48%

Values

	Fb (psi)	Fv (psi)	E (psi x mil)	Fc <sub>I</sub> (psi)
Reference Values	2400	240	1.8	650
Adjusted Values	2400	240	1.8	650

Adjustments

Cv Volume	1.000			
Cd Duration	1.00	1.00		
Cr Repetitive	1.00			
Ch Shear Stress		N/A		
Cm Wet Use	1.00	1.00	1.00	1.00
CI Stability	1.0000	Rb = 0.00	Le = 0.00 Ft	

Loads

	Uniform LL: 276	Uniform TL: 345 = A	Start	End
	Par Unif LL	Par Unif TL		
	348	H = 556	0	7.25

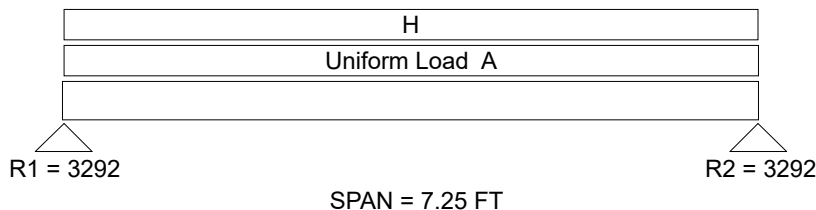

Uniform and partial uniform loads are lbs per lineal ft.

RANKIN

EX. OFFICE WIN

Date: 11/13/24

Selection (2) 1-3/4x 9-1/4 1.9E TJ Microllam LVL Lu = 0.0 Ft

Conditions NDS 2018

Min Bearing Area R1= 4.8 in<sup>2</sup> R2= 4.8 in<sup>2</sup> (1.5) DL Defl= 0.09 in

Data

Beam Span	8.0 ft	Reaction 1 LL	2496 #	Reaction 2 LL	2496 #
Beam Wt per ft	8.32 #	Reaction 1 TL	3637 #	Reaction 2 TL	3637 #
Bm Wt Included	67 #	Maximum V	3637 #		
Max Moment	7275 #	Max V (Reduced)	2936 #		
TL Max Defl	L / 240	TL Actual Defl	L / 420		
LL Max Defl	L / 360	LL Actual Defl	L / 710		

Attributes

	Section (in <sup>3</sup> )	Shear (in <sup>2</sup> )	TL Defl (in)	LL Defl
Actual	49.91	32.38	0.23	0.14
Critical	32.41	15.45	0.40	0.27
Status	OK	OK	OK	OK
Ratio	65%	48%	57%	51%

Values

	Fb (psi)	Fv (psi)	E (psi x mil)	Fc <sub>I</sub> (psi)
Reference Values	2600	285	1.9	750
Adjusted Values	2694	285	1.9	750

Adjustments

CF Size Factor	1.036			
Cd Duration	1.00	1.00		
Cr Repetitive	1.00			
Ch Shear Stress		N/A		
Cm Wet Use	1.00	1.00	1.00	1.00
CI Stability	1.0000	Rb = 0.00	Le = 0.00 Ft	

Loads

	Uniform LL: 276	Uniform TL: 345 = A		
	Par Unif LL	Par Unif TL	Start	End
	348	H = 556	0	8.0

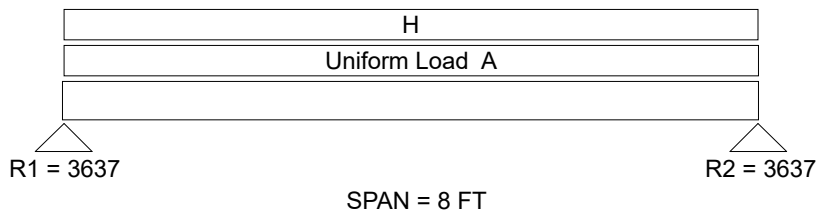

Uniform and partial uniform loads are lbs per lineal ft.

RANKIN

EX BATH WIN

Date: 11/13/24

Selection (2) 2x 10 HF #2 Lu = 0.0 Ft

Conditions NDS 2018

Min Bearing Area R1= 4.7 in<sup>2</sup> R2= 4.7 in<sup>2</sup> (1.5) DL Defl= 0.02 in

Data

Beam Span	4.7 ft	Reaction 1 LL	1278 #	Reaction 2 LL	1278 #
Beam Wt per ft	6.74 #	Reaction 1 TL	1898 #	Reaction 2 TL	1898 #
Bm Wt Included	32 #	Maximum V	1898 #		
Max Moment	2230 #'	Max V (Reduced)	1276 #		
TL Max Defl	L / 240	TL Actual Defl	L / >1000		
LL Max Defl	L / 360	LL Actual Defl	L / >1000		

Attributes

	Section (in <sup>3</sup> )	Shear (in <sup>2</sup> )	TL Defl (in)	LL Defl
Actual	42.78	27.75	0.04	0.02
Critical	28.63	12.76	0.24	0.16
Status	OK	OK	OK	OK
Ratio	67%	46%	18%	15%

Values

	Fb (psi)	Fv (psi)	E (psi x mil)	Fc <sub>I</sub> (psi)
Reference Values	850	150	1.3	405
Adjusted Values	935	150	1.3	405

Adjustments

CF Size Factor	1.100			
Cd Duration	1.00	1.00		
Cr Repetitive	1.00			
Ch Shear Stress		N/A		
Cm Wet Use	1.00	1.00	1.00	1.00
CI Stability	1.0000	Rb = 0.00	Le = 0.00 Ft	

Loads

	Uniform LL: 196	Uniform TL: 245 = A	Start	End
	Par Unif LL	Par Unif TL		
	348	H = 556	0	4.7

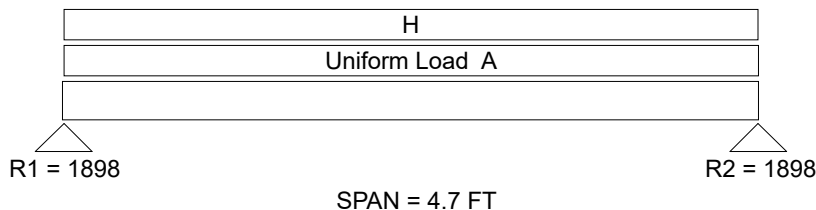

Uniform and partial uniform loads are lbs per lineal ft.

RANKIN

GREAT RM WIN

Date: 3/03/25

Selection      **3-1/8x 12 GLB 24F-V4 DF/DF**      Lu = 0.0 Ft

Conditions      NDS 2018  
 Min Bearing Area      R1= 5.0 in<sup>2</sup>    R2= 5.0 in<sup>2</sup>    (1.5) DL Defl= 0.19 in    Recom Camber= 0.29 in

Data

Beam Span	12.25 ft	Reaction 1 LL	1983 #	Reaction 2 LL	1983 #
Beam Wt per ft	9.11 #	Reaction 1 TL	3229 #	Reaction 2 TL	3229 #
Bm Wt Included	112 #	Maximum V	3229 #		
Max Moment	9887 #	Max V (Reduced)	2701 #		
TL Max Defl	L / 240	TL Actual Defl	L / 374		
LL Max Defl	L / 360	LL Actual Defl	L / 727		

Attributes

	Section (in <sup>3</sup> )	Shear (in <sup>2</sup> )	TL Defl (in)	LL Defl
Actual	75.00	37.50	0.39	0.20
Critical	49.44	16.88	0.61	0.41
Status	OK	OK	OK	OK
Ratio	66%	45%	64%	50%

Values

	Fb (psi)	Fv (psi)	E (psi x mil)	Fc <sub>I</sub> (psi)
Reference Values	2400	240	1.8	650
Adjusted Values	2400	240	1.8	650

Adjustments

Cv Volume	1.000			
Cd Duration	1.00	1.00		
Cr Repetitive	1.00			
Ch Shear Stress		N/A		
Cm Wet Use	1.00	1.00	1.00	1.00
CI Stability	1.0000	Rb = 0.00	Le = 0.00 Ft	

Loads      Uniform LL: 324      Uniform TL: 518 = A

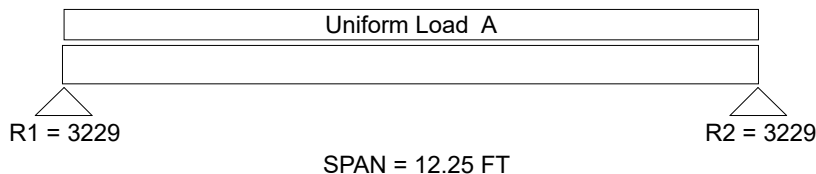

Uniform and partial uniform loads are lbs per lineal ft.

RANKIN

GREAT RM WIN

Date: 3/03/25

Selection      **3-1/8x 9 GLB 24F-V4 DF/DF**      Lu = 0.0 Ft

Conditions      NDS 2018

Min Bearing Area      R1= 3.7 in<sup>2</sup>      R2= 3.7 in<sup>2</sup>      (1.5) DL Defl= 0.15 in      Recom Camber= 0.22 in

Data

Beam Span	9.25 ft	Reaction 1 LL	1497 #	Reaction 2 LL	1497 #
Beam Wt per ft	6.83 #	Reaction 1 TL	2427 #	Reaction 2 TL	2427 #
Bm Wt Included	63 #	Maximum V	2427 #		
Max Moment	5613 #'	Max V (Reduced)	2034 #		
TL Max Defl	L / 240	TL Actual Defl	L / 369		
LL Max Defl	L / 360	LL Actual Defl	L / 712		

Attributes

	Section (in <sup>3</sup> )	Shear (in <sup>2</sup> )	TL Defl (in)	LL Defl
Actual	42.19	28.13	0.30	0.16
Critical	28.07	12.71	0.46	0.31
Status	OK	OK	OK	OK
Ratio	67%	45%	65%	51%

Values

	Fb (psi)	Fv (psi)	E (psi x mil)	Fc <sub>I</sub> (psi)
Reference Values	2400	240	1.8	650
Adjusted Values	2400	240	1.8	650

Adjustments

Cv Volume	1.000			
Cd Duration	1.00	1.00		
Cr Repetitive	1.00			
Ch Shear Stress		N/A		
Cm Wet Use	1.00	1.00	1.00	1.00
CI Stability	1.0000	Rb = 0.00	Le = 0.00 Ft	

Loads      Uniform LL: 324      Uniform TL: 518 = A

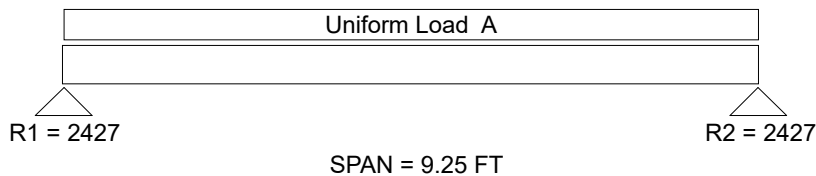

Uniform and partial uniform loads are lbs per lineal ft.

RANKIN

FN BM

Date: 11/13/24

Selection **6x 8 DF-L #2** Lu = 0.0 Ft

Conditions NDS 2018

Min Bearing Area R1= 4.1 in<sup>2</sup> R2= 4.1 in<sup>2</sup> (1.5) DL Defl= 0.01 in

Data

Beam Span	4.3 ft	Reaction 1 LL	2049 #	Reaction 2 LL	2049 #
Beam Wt per ft	10.02 #	Reaction 1 TL	2582 #	Reaction 2 TL	2582 #
Bm Wt Included	43 #	Maximum V	2582 #		
Max Moment	2776 #'	Max V (Reduced)	1832 #		
TL Max Defl	L / 240	TL Actual Defl	L / >1000		
LL Max Defl	L / 360	LL Actual Defl	L / >1000		

Attributes

	Section (in <sup>3</sup> )	Shear (in <sup>2</sup> )	TL Defl (in)	LL Defl
Actual	51.56	41.25	0.04	0.03
Critical	44.41	16.16	0.22	0.14
Status	OK	OK	OK	OK
Ratio	86%	39%	19%	21%

Values

	Fb (psi)	Fv (psi)	E (psi x mil)	Fc <sub>I</sub> (psi)
Reference Values	750	170	1.3	625
Adjusted Values	750	170	1.3	625

Adjustments

CF Size Factor	1.000			
Cd Duration	1.00	1.00		
Cr Repetitive	1.00			
Ch Shear Stress		N/A		
Cm Wet Use	1.00	1.00	1.00	1.00
CI Stability	1.0000	Rb = 0.00	Le = 0.00 Ft	

Loads

	Uniform LL: 476	Uniform TL: 596 = A	Start	End
	Par Unif LL	Par Unif TL		
	476	H = 596	0	4.3

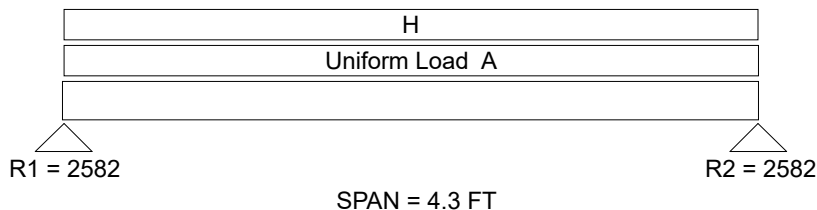

Uniform and partial uniform loads are lbs per lineal ft.

## LOADING ON SOUTH HOUSE WALLS:

### NEW ROOF LOAD:

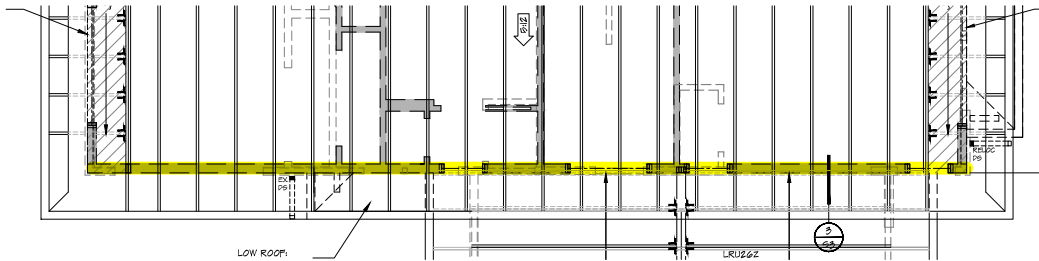

$$\text{DEAD LOAD} = 15 \text{ PSF} \times 13.5\text{ft} = 203 \text{ PLF}$$

$$\text{SNOW LOAD} = 25 \text{ PSF} \times 13.5\text{ft} = 338 \text{ PLF}$$

### NEW FLOOR LOAD:

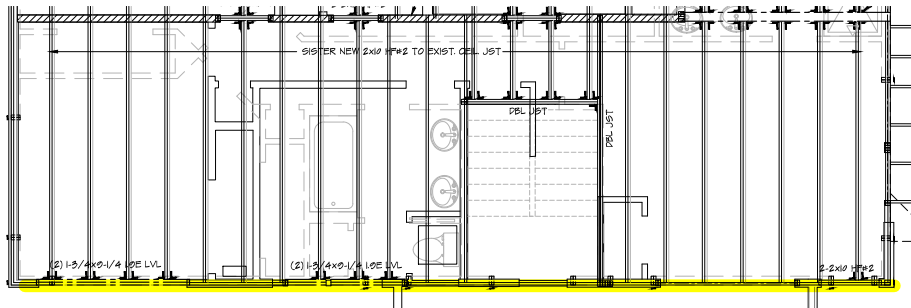

$$\text{DEAD LOAD} = 15 \text{ PSF} \times 7\text{ft} = 105 \text{ PLF}$$

$$\text{LIVE LOAD} = 40 \text{ PSF} \times 7\text{ft} = 280 \text{ PLF}$$

### EXISTING FLOOR LOAD:

$$\text{DEAD LOAD} = 15 \text{ PSF} \times 7\text{ft} = 105 \text{ PLF}$$

$$\text{LIVE LOAD} = 40 \text{ PSF} \times 7\text{ft} = 280 \text{ PLF}$$

### NEW & EXISTING WALL DEAD LOAD:

$$\text{DEAD LOAD} = 10 \text{ PSF} \times 16\text{ft} = 160 \text{ PLF}$$

### TOTAL LOADS:

$$\text{DEAD LOAD} = 203 + 105 + 105 + 160 = \mathbf{573 \text{ PLF}}$$

$$\text{LIVE LOAD} = 280 + 280 = \mathbf{560 \text{ PLF}}$$

$$\text{SNOW LOAD} = \mathbf{338 \text{ PLF}}$$

==> REQ MIN FOOTING: 1'-0" WIDE x 6" DEEP (SEE ENERCALC PRINTOUT)



PROJECT: Rankin Addition

DESCRIPTION: Loading on existing foundation

BY: NKH

DATE: 12/23/2024

JOB #: 24-123

## Wall Footing

Project File: (E) Foundation.ec6

LIC# : KW-06013860, Build:20.24.12.02

NKH Engineering

(c) ENERCALC, LLC 1982-2024

**DESCRIPTION:** Existing Foundation

### Code References

Calculations per ACI 318-19, IBC 2021

Load Combinations Used : ASCE 7-22 / IBC 2024 (L<=100psf)

### General Information

#### Material Properties

f'c : Concrete 28 day strength	=	3.0 ksi
fy : Rebar Yield	=	60.0 ksi
Ec : Concrete Elastic Modulus	=	3,122.0 ksi
Concrete Density	=	145.0 pcf
φ Values Flexure	=	0.90
Shear	=	0.750

#### Analysis Settings

Min Steel % Bending Reinf.	=	
Min Allow % Temp Reinf.	=	0.00180
Min. Overturning Safety Factor	=	1.0 : 1
Min. Sliding Safety Factor	=	1.0 : 1
AutoCalc Footing Weight as DL :	=	Yes

#### Soil Design Values

Allowable Soil Bearing	=	2.0 ksf
Increase Bearing By Footing Weight	=	Yes
Soil Passive Resistance (for Sliding)	=	250.0 pcf
Soil/Concrete Friction Coeff.	=	0.30

#### Increases based on footing Depth

Reference Depth below Surface	=	ft
Allow. Pressure Increase per foot of depth when base footing is below	=	ksf
	=	ft

#### Increases based on footing Width

Allow. Pressure Increase per foot of width when footing is wider than	=	ksf
	=	ft

#### Adjusted Allowable Bearing Pressure

= 2.073 ksf

### Dimensions

### Reinforcing

Footing Width	=	1.0 ft	Footing Thickness	=	6.0 in	Bars along X-X Axis	
Wall Thickness	=	4 in	Rebar Centerline to Edge of Concrete...			# of Bars in 12" Width	= 2
Wall center offset from center of footing	=	0 in	at Bottom of footing =		3.0 in	Reinforcing Bar Size	= # 4

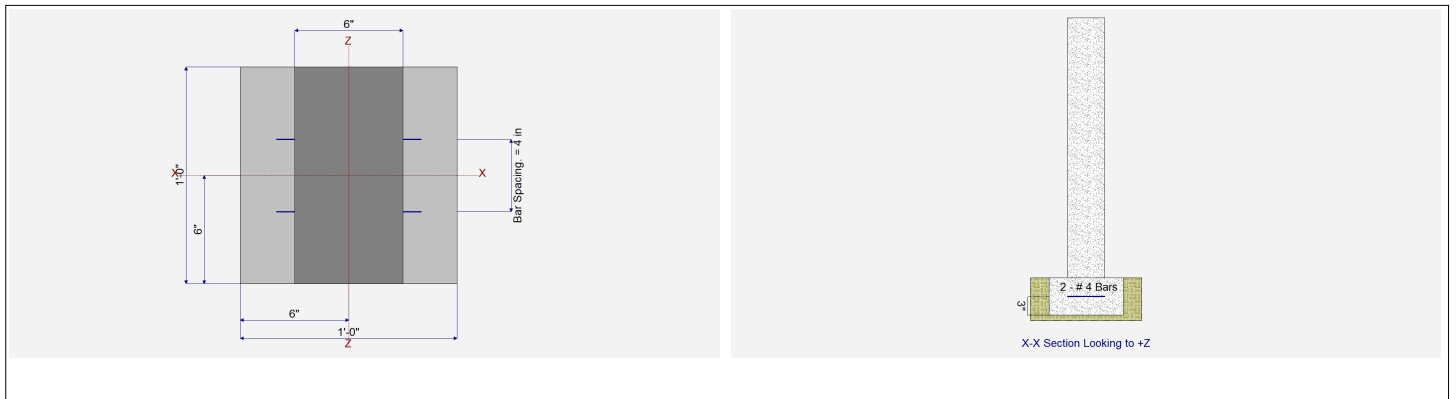

### Applied Loads

	D	Lr	L	S	W	E	H
P : Column Load	=						k
OB : Overburden	=	0.5730	0.560	0.3380			ksf
V-x	=						k
M-zz	=						k-ft
Vx applied	=	in above top of footing					

## Wall Footing

Project File: (E) Foundation.ec6

LIC#: KW-06013860, Build:20.24.12.02

NKH Engineering

(c) ENERCALC, LLC 1982-2024

**DESCRIPTION:** Existing Foundation

### DESIGN SUMMARY

**Design OK**

Factor of Safety	Item	Applied	Capacity	Governing Load Combination	
PASS	n/a	Overturing - Z-Z	0.0 k-ft	0.0 k-ft	No Overturing
PASS	n/a	Sliding - X-X	0.0 k	0.0 k	No Sliding
PASS	n/a	Uplift	0.0 k	0.0 k	No Uplift

Utilization Ratio	Item	Applied	Capacity	Governing Load Combination	
PASS	0.3174	Soil Bearing	0.6577 ksf	2.073 ksf	+D+0.750L+0.5250S
PASS	0.008250	Z Flexure (+X)	0.03873 k-ft	4.694 k-ft	+1.20D+1.60L+0.30S
PASS	0.001593	Z Flexure (-X)	0.007477 k-ft	4.694 k-ft	+1.20D+0.50L+0.150S
PASS	N/A	1-way Shear (+X)	N/A psi	73.333 psi	N/A
PASS	N/A	1-way Shear (-X)	N/A psi	73.333 psi	N/A

### Detailed Results

#### Soil Bearing

Rotation Axis & Load Combination...	Gross Allowable	Xecc	Actual Soil Bearing Stress		Actual / Allowable Ratio
			-X	+X	
D Only	2.073 ksf	0.0 in	0.3590 ksf	0.3590 ksf	0.173
+D+L	2.073 ksf	0.0 in	0.6390 ksf	0.6390 ksf	0.308
+D+0.70S	2.073 ksf	0.0 in	0.4773 ksf	0.4773 ksf	0.230
+D+0.750L	2.073 ksf	0.0 in	0.5690 ksf	0.5690 ksf	0.275
+D+0.750L+0.5250S	2.073 ksf	0.0 in	0.6577 ksf	0.6577 ksf	0.317
+0.60D	2.073 ksf	0.0 in	0.2154 ksf	0.2154 ksf	0.104
+D+0.750L+0.10S	2.073 ksf	0.0 in	0.5859 ksf	0.5859 ksf	0.283

Units : k-ft

#### Overturing Stability

Rotation Axis & Load Combination...	Overturing Moment	Resisting Moment	Stability Ratio	Status
Footing Has NO Overturing				

#### Sliding Stability

Force Application Axis Load Combination...	Sliding Force	Resisting Force	Sliding SafetyRatio	Status
Footing Has NO Sliding				

#### Footing Flexure

Flexure Axis & Load Combination	Mu k-ft	Which Side ?	Tension @ Bot. or Top ?	As Req'd in^2	Gvrn. As in^2	Actual As in^2	Phi*Mn k-ft	Status
+1.40D	0.009363	-X	Top	0.1296	Min Temp %	0.4	4.694	OK
+1.40D	0.009363	+X	Top	0.1296	Min Temp %	0.4	4.694	OK
+1.20D+1.60L	0.03398	-X	Bottom	0.1296	Min Temp %	0.4	4.694	OK
+1.20D+1.60L	0.03398	+X	Bottom	0.1296	Min Temp %	0.4	4.694	OK
+1.20D+1.60L+0.30S	0.03873	-X	Bottom	0.1296	Min Temp %	0.4	4.694	OK
+1.20D+1.60L+0.30S	0.03873	+X	Bottom	0.1296	Min Temp %	0.4	4.694	OK
+1.20D+0.50L	0.0051	-X	Bottom	0.1296	Min Temp %	0.4	4.694	OK
+1.20D+0.50L	0.0051	+X	Bottom	0.1296	Min Temp %	0.4	4.694	OK
+1.20D	0.008025	-X	Top	0.1296	Min Temp %	0.4	4.694	OK
+1.20D	0.008025	+X	Top	0.1296	Min Temp %	0.4	4.694	OK
+1.20D+0.50L+S	0.02094	-X	Bottom	0.1296	Min Temp %	0.4	4.694	OK
+1.20D+0.50L+S	0.02094	+X	Bottom	0.1296	Min Temp %	0.4	4.694	OK
+1.20D+S	0.007819	-X	Bottom	0.1296	Min Temp %	0.4	4.694	OK
+1.20D+S	0.007819	+X	Bottom	0.1296	Min Temp %	0.4	4.694	OK
+1.20D+0.50L+0.30S	0.009853	-X	Bottom	0.1296	Min Temp %	0.4	4.694	OK
+1.20D+0.50L+0.30S	0.009853	+X	Bottom	0.1296	Min Temp %	0.4	4.694	OK
+0.90D	0.006019	-X	Top	0.1296	Min Temp %	0.4	4.694	OK
+0.90D	0.006019	+X	Top	0.1296	Min Temp %	0.4	4.694	OK
+1.20D+0.50L+0.150S	0.007477	-X	Bottom	0.1296	Min Temp %	0.4	4.694	OK
+1.20D+0.50L+0.150S	0.007477	+X	Bottom	0.1296	Min Temp %	0.4	4.694	OK

Units : k

#### One Way Shear

Load Combination...	vu @ -X	vu @ +X	vu:Max	Φ vn	vu / Φ vn	Status
+1.40D	0.0 psi	0.0 psi	0.0 psi	73.3 psi	0.000	OK
+1.20D+1.60L	0.0 psi	0.0 psi	0.0 psi	73.3 psi	0.000	OK

Project Title: Rankin Addition  
 Engineer: NKH  
 Project ID: 24-123  
 Project Descr:

**Wall Footing**

Project File: (E) Foundation.ec6

LIC# : KW-06013860, Build:20.24.12.02

NKH Engineering

(c) ENERCALC, LLC 1982-2024

**DESCRIPTION:** Existing Foundation

**One Way Shear**

Units : k

Load Combination...	vu @ -X	vu @ +X	vu:Max	$\phi$ vn	vu / $\phi$ vn	Status
+1.20D+1.60L+0.30S	0.0 psi	0.0 psi	0.0 psi	73.3 psi	0.000	OK
+1.20D+0.50L	0.0 psi	0.0 psi	0.0 psi	73.3 psi	0.000	OK
+1.20D	0.0 psi	0.0 psi	0.0 psi	73.3 psi	0.000	OK
+1.20D+0.50L+S	0.0 psi	0.0 psi	0.0 psi	73.3 psi	0.000	OK
+1.20D+S	0.0 psi	0.0 psi	0.0 psi	73.3 psi	0.000	OK
+1.20D+0.50L+0.30S	0.0 psi	0.0 psi	0.0 psi	73.3 psi	0.000	OK
+0.90D	0.0 psi	0.0 psi	0.0 psi	73.3 psi	0.000	OK
+1.20D+0.50L+0.150S	0.0 psi	0.0 psi	0.0 psi	73.3 psi	0.000	OK



# Rankin Addition

Project Number: 24-123  
3633 Island Crest Way  
Mercer Island, WA 98040

## Structural Calculations (Lateral Only)

Calculations.....S1 – S63



Reviewed by:  
Nabil Kausal-Hayes, PE  
206-601-9728  
[www.nkhengineering.com](http://www.nkhengineering.com)

Prepared By:  
Allen Rishel, EIT

**December 26th, 2024**



PROJECT: Rankin Addition

DESIGNER: NKH and AKR

DATE: December 26th, 2024

JOB #: 24-123

## PROJECT SUMMARY AND DESIGN CRITERIA

### Background

#### Project Summary:

This is an upper floor addition on an existing single story, wood framed house for the Rankin Family on Mercer Island, WA. The structure consists of wood roof and floor trusses/joists bearing on wood framed walls, posts, and beams. The house is supported by existing concrete stem walls and shallow spread footings. This project is designed in accordance with the 2021 International Building Code along with the codes listed below and corresponding state and city/county amendments.

### Notes:

All input variables are highlighted in yellow, resources bolded, and links to resources bolded and underlined. Areas highlighted in blue are code/design checks and green - unity checks.

### Resources:

- American Wood Council (AWC). (2018). "National Design Specifications for Wood Construction (NDS)."
- American Wood Council (AWC). (2021). "Special Design Provisions for Wind and Seismic (SDWS)."
- American Concrete Institute (ACI). (2019). "Building Code Requirements for Structural Concrete (ACI 318-19)."
- American Institute of Steel Construction (AISC). (2016). "Steel Construction Manual." 15th Ed.
- American Society of Civil Engineers (ASCE). (2022). "Minimum Design Loads for Buildings and Other Structures."
- State of Washington (2021). "International Building Code (IBC)."
- American Society of Civil Engineering (ASCE). "ASCE Hazard Tool"<https://asce7hazardtool.online/>

### Material Properties

#### Soil:

- Soil Bearing Pressure (min per IBC1806.2)
- Frost Depth
- Active and Passive Soil Pressure

$$p_{brg} := 2000 \text{ psf}$$

$$FD := 12 \text{ in}$$

$$q_a := 35 \cdot pcf \quad q_p := 250 \cdot pcf$$

$$f'_c := 2500 \text{ psi}$$

$$Y_{conc} := 150 \cdot pcf$$

$$Y_{conc LW} := 115 \cdot pcf$$

$$f_{yr} := 60 \text{ ksi}$$

$$E_c := 29000 \text{ ksi}$$

$$F_{nv} := 24 \text{ ks} \quad F_{nt} := 45 \text{ ksi}$$

#### Concrete:

- Compressive Strength
- Density, Normal Weight
- Density, Light Weight
- Reinforcing Steel, ASTM A615

#### Steel:

- Modulus of Elasticity
- Anchor Rods/Bolts, ASTM A307 Shear and Tension Yield Strength

#### Wood:

- Solid Sawn Joists, Beams, Headers, and Studs
- Glulam Beams

DF-L #1 6x and Larger, DF-L #2 All Other (UNO)  
24F-V4 (Simple Span), 24F-V8 (Cont/Cantilever)

**Gravity Loading****Roof Dead Load**

Roofing	$R := 1.5 \text{ psf}$
Insulation	$I := 2.0 \text{ psf}$
Ceiling	$C := 2 \text{ psf}$
Sheathing	$t := 0.5 \text{ in}$ $SH := t \cdot \left( \frac{3.25 \text{ psf}}{1 \text{ in}} \right) = 1.625 \text{ psf}$
Structural Members	$S := 2.5 \text{ psf}$
Lights	$L := 1 \text{ psf}$
Mechanical	$M := 1.5 \text{ psf}$
Misc.	$MISC := 2.9 \text{ psf}$

$$DL_{rf} := R + I + C + SH + S + L + M + MISC$$

$$DL_{rf} = 15 \text{ psf}$$

$$DL_{pv} := 0 \text{ psf}$$

**Seismic Roof Dead Load**

$$SDL_{rf} := DL_{rf} - MISC + DL_{pv} \cdot (75 \%) = 12.1 \text{ psf}$$

$$SDL_{rf} = 12 \text{ psf}$$

**Floor Dead Load**

Flooring	$F := 1.5 \text{ psf}$
Insulation	$I := 2.0 \text{ psf}$
Ceiling	$C := 0 \text{ psf}$
Sheathing	$t := 0.75 \text{ in}$ $SH := t \cdot \left( \frac{3.25 \text{ psf}}{1 \text{ in}} \right) = 2.4375 \text{ psf}$
Structural Members	$S := 3.4 \text{ psf}$
Lights	$L := 1 \text{ psf}$
Mechanical	$M := 1.5 \text{ psf}$
Misc.	$MISC := 3.2 \text{ psf}$

$$DL_{flr} := F + I + C + SH + S + L + M + MISC$$

$$DL_{flr} = 15 \text{ psf}$$

**Seismic Floor Dead Load**

$$SDL_{flr} := DL_{flr} = 719.9994 \text{ Pa}$$

$$SDL_{flr} = 15 \text{ psf}$$

**Wall Dead Loads**

Exterior Wood	$P_{ext\_w} := 10 \text{ psf}$
Interior Wood	$P_{int} := 9 \text{ psf}$

**Live Loads**

Roof	$LL_{rf} := 20 \text{ psf}$	Roof Snow Load	$SL := 25 \text{ psf}$
Floor Live Load	$LL_{flr} := 40 \text{ psf}$		
Deck Live Load	$LL_{deck} := 1.5 \cdot LL_{flr} = 60 \text{ psf}$		

**Deflection Criteria**

$$\Delta_{rf\_TL} := \frac{L}{240} \quad \Delta_{rf\_LL} := \frac{L}{360} \quad \Delta_{flr\_TL} := \frac{L}{360} \quad \Delta_{flr\_LL} := \frac{L}{480}$$



PROJECT: Rankin Addition

DESIGNER: NKH and AKR

DATE: December 26th, 2024

JOB #: 24-123

## LATERAL ANALYSIS

### General

Input

Output

Verify

### LRFD

#### Risk Cat.: II (ref. 1.5-1)

$$L := 48 \text{ ft}$$

Building Length

$$SDL_{rf} := 12 \text{ psf}$$

Roof Seismic Dead Load

$$B := 48 \text{ ft}$$

Building Width

$$SDL_{flr} := 15 \text{ psf}$$

Floor Seismic Dead Load

$$h_{rf} := 20 \text{ ft}$$

Avg Roof Height Upper

$$LL := 25 \text{ psf}$$

Roof Snow/Live Load

$$h_p := 0 \text{ ft}$$

Parapet Height

$$P_{ext} := 12 \text{ psf}$$

Exterior Wall Load

$$h_{wall} := 9 \text{ ft}$$

Wall Height

$$P_{int} := 10 \text{ psf}$$

Interior Wall Load

$$a := \min \left( \begin{bmatrix} 10 \% \cdot B \\ 0.4 \cdot h_{rf} \end{bmatrix} \right) = 4.8 \text{ ft}$$

Width of Pressure Coefficient Zone

### MWFRS (per ASCE 7 - 22, Chapter 26 and 27)

$$\theta := \text{atan} \left( \frac{5}{12} \right) = 22.62 \text{ deg}$$

Roof Slope

#### Design Velocity Pressure - Enclosed/Partially Enclosed Buildings

$$V_w := 110 \text{ mph}$$

Basic Wind Speed (ref. figure 26.5-1A and city/county design criteria)

$$K_d := 0.85$$

Directionality Factor (ref. section 26.6 and table 26.6 - 1)

$$\text{exposure} := \text{"B"}$$

Exposure Category (ref. section 26.7)

$$K_{zt} := 1.3$$

Topographic Factor (ref. section 26.8)

$$K_z = 0.62$$

Velocity Pressure Exposure Coefficient (ref. table 26.10-1)

$$q_z := 0.00256 \cdot K_z \cdot K_{zt} \cdot K_d \cdot V_w^2 \cdot (\text{psf}) \text{ Velocity pressure (eq 27.3-1)}$$

$$q_z = 21.2 \text{ psf}$$

#### Design Wind Pressure

$$P_{w\_min} := 16 \text{ psf}$$

Minimum Design Pressure

$$G_e := 0.85$$

Gust Effect Factor (ref. section 26.9)

#### Walls

$$GC_{pi} := 0.18$$

Internal Pressure Coefficient (ref. table 26.11-1)

Velocity Pressure Evaluated at Mean Roof Height,  $h$ 

$$q_h := q_z = 21.22 \text{ psf}$$

**Design Wind Pressure (cont'd)**

External Pressure Coefficients for Walls (ref. figure 26.4-1)

$$\frac{L}{B} = 1 \quad C_{pww} := 0.8 \quad \text{Windward Wall} \quad C_{plw} := -0.25 \quad \text{Leeward Wall}$$

$$C_p := C_{pww} - C_{plw} = 1.05$$

Design MWFRS Wind Pressures (eq 26.4-1)

$$p_w := \max \left( \left[ \begin{array}{c} p_{w\_min} \\ q_h \cdot (G_e \cdot C_p + GC_{pi}) \\ q_h \cdot (G_e \cdot C_p - GC_{pi}) \end{array} \right] \right) \quad p_w = 22.76 \text{ psf}$$

Parapet (ref. section 27.4.5)

$$q_h \cdot (G_e \cdot C_p - GC_{pi}) = 15.12 \text{ psf}$$

 $GC_{pnw} := 1.5$  Windward Combined Net Pressure Coefficient

 $GC_{pnL} := -1.0$  Leeward Combined Net Pressure Coefficient

$$p_p := \text{if } h_p \leq 0 \text{ psf} \quad \text{Combined Net Pressure on Parapet} \quad p_p = 0 \text{ psf}$$

$$\text{else } q_z \cdot (GC_{pnw} - GC_{pnL})$$

Roof (fig. 27.4-1)

$$\frac{h_{rf}}{L} = 0.4167$$

 $GC_{pi} = 0.18$  Internal pressure coefficient (ref. table 26.11-1)

External pressure coefficients for roofs (ref. figure 27.4-1)

$$\frac{h_{rf}}{L} = 0.4167 \quad C_{prf1} := -0.6 \quad C_{prf2} := 0.2$$

Velocity pressure evaluated at mean roof height, h

$$q_h = 21.22 \text{ psf}$$

Design MWFRS wind pressure (ref. eq 27.4-1)

$$p_{rf\_pos1} := q_h \cdot (G_e \cdot C_{prf1} + GC_{pi}) = -7 \text{ psf} \quad p_{rf\_pos2} := q_h \cdot (G_e \cdot C_{prf2} + GC_{pi}) = 7.43 \text{ psf}$$

$$p_{rf\_neg1} := q_h \cdot (G_e \cdot C_{prf1} - GC_{pi}) = -14.64 \text{ psf} \quad p_{rf\_neg2} := q_h \cdot (G_e \cdot C_{prf2} - GC_{pi}) = -0.21 \text{ psf}$$

$$p_{rf} := |p_{rf\_neg1}| = 14.6429 \text{ psf} \quad P_{rf\_horiz} := p_{rf} \cdot \sin(\theta) = 5.6319 \text{ psf}$$

$$p_{w\_up} := 0.6 \cdot SDL_{rf} + 0.6 \cdot \min \left( \left[ \begin{array}{c} P_{rf\_neg1} \\ P_{rf\_neg2} \end{array} \right] \right) \quad \text{Net uplift pressure (ASD)} \quad p_{w\_up} = -1.59 \text{ psf}$$

Roof Overhangs

 $C_{poh} := -0.8$  External pressure coefficients for roof overhangs (ref. 27.5.3)

$$p_{oh} := q_z \cdot (G_e \cdot C_{poh}) + \min \left( \left[ \begin{array}{c} P_{rf\_neg1} \\ P_{rf\_neg2} \end{array} \right] \right) \quad \text{Overhang pressure} \quad p_{oh} = -29.07 \text{ psf}$$

$$OH_{net} := 0.6 \cdot SDL_{rf} + 0.6 \cdot p_{oh} \quad \text{Net uplift pressure (ASD)} \quad OH_{net} = -10.24 \text{ psf}$$

**C+C (per ASCE 7 - 22, Chapter 30)**Walls (ref. eq. 30.4-1 and figure 30.4-1)

$$GC_{pw4\_pos} := 1.0$$

$$GC_{pw4\_neg} := -1.1$$

exterior pressure coefficients

$$GC_{pw5\_pos} := 1.0$$

$$GC_{pw5\_neg} := -1.4$$

exterior pressure coefficients (corner zone)

$$P_{cc\_w4pos} := q_h \cdot (GC_{pw4\_pos} + GC_{pi}) = 25.04 \text{ psf}$$

Positive design wind pressure (ref. eq. 30.4-1)

$$P_{cc\_w4neg} := q_h \cdot (GC_{pw4\_neg} - GC_{pi}) = -27.16 \text{ psf}$$

Negative design wind pressure

$$P_{cc\_w5pos} := q_h \cdot (GC_{pw5\_pos} + GC_{pi}) = 25.04 \text{ psf}$$

Corner zone positive design wind pressure

$$P_{cc\_w5neg} := q_h \cdot (GC_{pw5\_neg} - GC_{pi}) = -33.53 \text{ psf}$$

Corner zone negative design wind pressure

Roofs (ref. eq. 30.4-1 and figure 30.4-2B)

Negative design wind pressure

$$GC_{pr1} := -0.9$$

$$GC_{pr2} := -1.7$$

$$GC_{pr3} := -2.6$$

$$P_{cc\_r1} := q_h \cdot (GC_{pr1} - GC_{pi}) = -22.92 \text{ psf}$$

$$P_{cc\_r3} := q_h \cdot (GC_{pr3} - GC_{pi}) = -59 \text{ psf}$$

$$P_{cc\_r2} := q_h \cdot (GC_{pr2} - GC_{pi}) = -39.9 \text{ psf}$$

Positive design wind pressure

$$GC_{pr\_pos} := 0.5$$

$$P_{cc\_r2} := q_h \cdot (GC_{pr\_pos} + GC_{pi}) = 14.43 \text{ psf}$$

**Wind Diaphragm Shear (LRFD)**

$$A_{wall\_L} := 760 \text{ ft}^2$$

$$A_{roof\_L} := 300 \text{ ft}^2$$

$$A_{wall\_T} := 640 \text{ ft}^2$$

$$A_{roof\_T} := 140 \text{ ft}^2$$

$$V_{wu\_L} := p_w \cdot A_{wall\_L} + p_{rf\_horiz} \cdot A_{roof\_L} = 18.99 \text{ kip}$$

Longitudinal diaphragm shear

$$V_{wu\_T} := p_w \cdot A_{wall\_T} + p_{rf\_horiz} \cdot A_{roof\_T} = 15.36 \text{ kip}$$

Transverse diaphragm shear

**Seismic (per ASCE 7 - 22, 12.8)****LRFD**Basic Parameters

- Equivalent Lateral Force Procedure (ELFP)
- Site class: D
- Seismic design category: D
- Light Framed Wood Walls Sheathed w/ Wood Panels

$$I_s := 1.0$$

Seismic importance factor (ref. table 1.5-2)

$$S_{DS} := 0.939$$

Design spectral acceleration parameter (ref. ASCE Summary Report)

$$R := 6.5$$

Response modification factor - (ref. table 12.2-1)

$$\Omega_o := 3$$

System overstrength factor (ref. table 12.2-1)

$$C_d := 4$$

Deflection amp. factor (ref. table 12.2-1)

$$\rho := 1.0$$

Redundancy factor (ref section 12.3.4)

$$C_s := \frac{S_{DS}}{\left(\frac{R}{I_s}\right)} = 0.1445$$

Seismic response coefficient (EQ. 12.8 - 2)

$$S_{D1} := 0.88$$

$$S_1 := 0.49$$

$$h_n := h_{rf} = 20 \text{ ft}$$

Highest level of structure

$$h_{in} := 10 \text{ ft}$$

Interior wall height

$$C_t := 0.02$$

$$x := 0.75$$

Table 12.8-2

$$T_a := C_t \cdot \left(\frac{h_n}{\text{ft}}\right)^x = 0.1891$$

EQ 12.8-7

$$C_{smax} := \frac{S_{D1}}{T_a \cdot \left(\frac{R}{I_s}\right)}$$

$$C_{smax} = 0.7158$$

$$C_s := \max \left( \left[ \min \left( \left[ \begin{array}{c} 0.1 \\ C_s \\ C_{smax} \end{array} \right] \right) \right] \right)$$

$$C_s = 0.1445$$

$$C_{s\_min} := \frac{0.5 \cdot S_{D1}}{\left(\frac{R}{I_s}\right)} = 0.0677$$

EQ 12.8- 5 and 12.8- 6

$$C_s := \rho \cdot C_s$$

$$C_s = 0.144$$

## Seismic Diaphragm Shear

### Building Weights Contributing to Seismic Forces

$$W_{diaphragm\_rf} := 1450 \text{ ft}^2 \cdot SDL_{rf}$$

$$W_{diaphragm\_flr} := 1750 \text{ ft}^2 \cdot SDL_{flr}$$

$$W_{diaphragm} := W_{diaphragm\_rf} + W_{diaphragm\_flr}$$

$$W_{walls\_T} := (p_{ext} + p_{int}) \cdot A_{wall\_T} \cdot 2$$

$$W_{walls\_T} = 28.16 \text{ kip}$$

$$W_{walls\_L} := (p_{ext} + p_{int}) \cdot A_{wall\_L} \cdot 2$$

$$W_{walls\_L} = 33.44 \text{ kip}$$

### Shear Loads

$$V_{su} := C_s \cdot (W_{diaphragm} + W_{walls\_L} + W_{walls\_T})$$

$$V_{su} = 15.2046 \text{ kip}$$

### Lateral Summary

Seismic /Wind Shearwall Capacity Factor  
(ref. NDS Shearwall Capacities)

$$C_{sw\_cap} := \frac{310 \text{ psf}}{435 \text{ psf}} = 0.71$$

Transverse

Wind

$$V_{wu\_T} := 0.6 \cdot V_{wu\_T} \cdot C_{sw\_cap} = 6.57 \text{ kip}$$

Seismic

$$V_{su\_L} := 0.7 \cdot V_{su} \cdot C_{sw\_cap} = 7.58 \text{ kip}$$

```
V_T := if V_wu_T > V_su_L      = "SEISMIC CONTROLS"
      "WIND CONTROLS"
      else
      "SEISMIC CONTROLS"
```

Longitudinal

$$V_{wu\_L} := 0.6 \cdot V_{wu\_L} \cdot C_{sw\_cap} = 8.12 \text{ kip}$$

$$V_{su\_T} := 0.7 \cdot V_{su} \cdot C_{sw\_cap} = 7.58 \text{ kip}$$

```
V_L := if V_wu_L > V_su_T      = "WIND CONTROLS"
      "WIND CONTROLS"
      else
      "SEISMIC CONTROLS"
```

**Wall Line Wind Force Reactions - Roof**

$$h_{wall} = 9 \text{ ft}$$

Average Wall Height

$$h_{rf\_proj} := 6 \text{ ft}$$

Roof Projection above wall

$$p_w = 22.76 \text{ psf}$$

Design Wind Pressure (ref. 'Wind Loading')

$$p_{rf\_horiz} = 5.63 \text{ psf}$$

Design Wind Pressure (ref. 'Wind Loading')

**Longitudinal Wall Line Reactions**

Reaction 1 
$$trib1 := \frac{46 \text{ ft}}{2} = 23 \text{ ft}$$

$$R_{Lrf\_1} := \left( p_w \cdot \frac{h_{wall}}{2} + p_{rf\_horiz} \cdot h_{rf\_proj} \right) \cdot trib1$$

$$R_{Lrf\_1} = 3.13 \text{ kip}$$

Reaction 2 
$$trib2 := \frac{46 \text{ ft}}{2} = 23 \text{ ft}$$

$$R_{Lrf\_2} := \left( p_w \cdot \frac{h_{wall}}{2} + p_{rf\_horiz} \cdot h_{rf\_proj} \right) \cdot (trib2)$$

$$R_{Lrf\_2} = 3.13 \text{ kip}$$

**Transverse Wall Line Reactions**

Reaction A 
$$tribA := \frac{24 \text{ ft}}{2} = 12 \text{ ft}$$

$$R_{Trf\_A} := \left( p_w \cdot \frac{h_{wall}}{2} + p_{rf\_horiz} \cdot h_{rf\_proj} \right) \cdot tribA$$

$$R_{Trf\_A} = 1.63 \text{ kip}$$

Reaction B 
$$tribB := \frac{24 \text{ ft}}{2} = 12 \text{ ft}$$

$$R_{Trf\_B} := \left( p_w \cdot \frac{h_{wall}}{2} + p_{rf\_horiz} \cdot h_{rf\_proj} \right) \cdot (tribB)$$

$$R_{Trf\_B} = 1.63 \text{ kip}$$

**Vertical Distribution of Seismic Forces - Roof Diaphragm (Per ASCE 7- 22, 12.8.3)**

$$V_{su} = 15.2046 \text{ kip}$$

$$C_{vx\_roof} := \frac{\left( W_{diaphragm\_rf} + W_{walls\_L} \cdot \frac{1}{4} + W_{walls\_T} \cdot \frac{1}{4} \right)}{\left( W_{diaphragm} + W_{walls\_L} + W_{walls\_T} \right)} = 0.3116$$

$$V_{rf} := V_{su} \cdot C_{vx\_roof}$$

Distributed shear to roof

$$V_{rf} = 4.74 \text{ kip}$$

**Wall Line Seismic Force Reactions - Roof****Longitudinal**

$$\text{Reaction 1} \quad R_{Lrf\_1\_EL} := \frac{trib1}{46 \text{ ft}} \cdot V_{rf}$$

$$R_{Lrf\_1\_EL} = 2.37 \text{ kip}$$

$$\text{Reaction 2} \quad R_{Lrf\_2\_EL} := \frac{trib2}{46 \text{ ft}} \cdot V_{rf}$$

$$R_{Lrf\_2\_EL} = 2.37 \text{ kip}$$

**Transverse**

$$\text{Reaction A} \quad R_{Trf\_A\_EL} := \frac{tribA}{24 \text{ ft}} \cdot V_{rf}$$

$$R_{Trf\_A\_EL} = 2.37 \text{ kip}$$

$$\text{Reaction B} \quad R_{Trf\_B\_EL} := \frac{tribB}{24 \text{ ft}} \cdot V_{rf}$$

$$R_{Trf\_B\_EL} = 2.37 \text{ kip}$$

**Wall Line Wind Force Reactions - Upper Floor**

$$h_{wall} = 9 \text{ ft}$$

Average Wall Height

$$p_w = 22.76 \text{ psf}$$

Design Wind Pressure (ref. 'Wind Loading')

Longitudinal Grid Line Reactions

Reaction 1 
$$trib1 := \frac{20 \text{ ft}}{2} = 10 \text{ ft}$$

$$R_{Lup\_1} := (p_w \cdot h_{wall}) \cdot trib1 + R_{Lrf\_1}$$

$$R_{Lup\_1} = 5.18 \text{ kip}$$

Reaction 2 
$$trib2 := \frac{26 \text{ ft}}{2} = 13 \text{ ft}$$

$$R_{Lup\_2} := (p_w \cdot h_{wall}) \cdot (trib1 + trib2)$$

$$R_{Lup\_2} = 4.71 \text{ kip}$$

Reaction 3 
$$trib3 := 10 \text{ ft} = 10 \text{ ft}$$

$$R_{Lup\_3} := (p_w \cdot h_{wall}) \cdot (trib3) + R_{Lrf\_2}$$

$$R_{Lup\_3} = 5.18 \text{ kip}$$

Transverse Wall Line Reactions

Reaction A 
$$tribA := \frac{24 \text{ ft}}{2} = 12 \text{ ft}$$

$$R_{Tup\_A} := (p_w \cdot h_{wall}) \cdot tribA + R_{Trf\_A}$$

$$R_{Tup\_A} = 4.09 \text{ kip}$$

Reaction B 
$$tribB := \frac{24 \text{ ft}}{2} = 12 \text{ ft}$$

$$R_{Tup\_B} := (p_w \cdot h_{wall}) \cdot (tribA + tribB) + R_{Trf\_B}$$

$$R_{Tup\_B} = 6.55 \text{ kip}$$

Reaction C 
$$tribC := tribB = 12 \text{ ft}$$

$$R_{Tup\_C} := (p_w \cdot h_{wall}) \cdot (tribC)$$

$$R_{Tup\_C} = 2.46 \text{ kip}$$

**Vertical Distribution of Seismic Forces - Upper Floor Diaphragm (Per ASCE 7- 22, 12.8.3)**

$$V_{su} = 15.2046 \text{ kip}$$

$$C_{vx\_up} := \frac{\left( W_{diaphragm\_flr} + W_{walls\_L} \cdot \frac{1}{2} + W_{walls\_T} \cdot \frac{1}{2} \right)}{\left( W_{diaphragm} + W_{walls\_L} + W_{walls\_T} \right)} = 0.542$$

$$V_{up} := V_{su} \cdot C_{vx\_up}$$

Distributed shear to roof

$$V_{up} = 8.24 \text{ kip}$$

**Wall Line Seismic Force Reactions - Upper Floor****Longitudinal**

$$\text{Reaction 1} \quad R_{Lup\_1\_EL} := \frac{trib1}{L} \cdot V_{up} + R_{Lrf\_1\_EL}$$

$$R_{Lup\_1\_EL} = 4.09 \text{ kip}$$

$$\text{Reaction 2} \quad R_{Lup\_2\_EL} := \frac{trib1 + trib2}{L} \cdot V_{up}$$

$$R_{Lup\_2\_EL} = 3.95 \text{ kip}$$

$$\text{Reaction 3} \quad R_{Lup\_3\_EL} := \frac{trib3}{L} \cdot V_{up} + R_{Lrf\_2\_EL}$$

$$R_{Lup\_3\_EL} = 4.09 \text{ kip}$$

**Transverse**

$$\text{Reaction A} \quad R_{Tup\_A\_EL} := \frac{tribA}{B} \cdot V_{up} + R_{Trf\_A\_EL}$$

$$R_{Tup\_A\_EL} = 4.43 \text{ kip}$$

$$\text{Reaction B} \quad R_{Tup\_B\_EL} := \frac{tribA + tribB}{B} \cdot V_{up} + R_{Trf\_B\_EL}$$

$$R_{Tup\_B\_EL} = 6.49 \text{ kip}$$

$$\text{Reaction C} \quad R_{Tup\_C\_EL} := \frac{tribC}{B} \cdot V_{up}$$

$$R_{Tup\_C\_EL} = 2.06 \text{ kip}$$

**Diaphragm Check (ref. ANSI/AF+PA SDPWS-2021)**Aspect Ratio

$$L_T := L = 48 \text{ ft}$$

$$L_L := B = 48 \text{ ft}$$

Length and width of diaphragm

$$check_D := \text{if } \frac{L_L}{L_T} > 4$$

"NG"

else

"OK"

$$ratio := \frac{L_L}{L_T} = 1$$

**check\_D = "OK"**Diaphragm Shear

Shear capacities for 19/32" APA Rated OSB/Plywood Sheathing - Un-Blocked (ref. table 4.2A):

$$\Omega_{D_w} := 2.0$$

Wind ASD reduction factor

$$v_{w6} := 800 \cdot plf \cdot \frac{1}{\Omega_{D_w}} = 400 \text{ plf}$$

Allowable Shear Capacity- 10d's @ 6" oc

$$\Omega_{D_s} := 2.8$$

Seismic ASD reduction factor

$$v_{s6} := 800 \cdot plf \cdot \frac{1}{\Omega_{D_s}} = 285.7 \text{ plf}$$

Allowable Shear Capacity- 10d's @ 6" oc

Diaphragm

$$V_{diaphT_{WL}} := 0.6 \cdot R_{TuP_B} = 3.93 \text{ kip}$$

Wind diaphragm shear transverse direction

$$V_{diaphL_{WL}} := 0.6 \cdot R_{LuP_2} = 2.83 \text{ kip}$$

Wind diaphragm shear longitudinal direction

$$V_{diaphT_{EL}} := 0.7 \cdot R_{TuP_B_{EL}} = 4.54 \text{ kip}$$

Seismic diaphragm shear transverse direction

$$V_{diaphL_{EL}} := 0.7 \cdot R_{LuP_2_{EL}} = 2.76 \text{ kip}$$

Seismic diaphragm shear longitudinal direction

Longitudinal Diaphragm Shear

$$v_{L_w} := \frac{V_{diaphL_{WL}}}{L_T} = 58.89 \text{ plf}$$

$$v_{L_s} := \frac{V_{diaphL_{EL}}}{L_T} = 57.59 \text{ plf}$$

6" Nailing

$$Check_w := \text{if } v_{L_w} \leq v_{w6} = \text{"OK"}$$

"OK"

else

"NG!!"

$$Check_s := \text{if } v_{L_s} \leq v_{s6} = \text{"OK"}$$

"OK"

else

"NG!!"

Transverse Base Shear

$$v_{T_w} := \frac{V_{diaphT_{WL}}}{L_L} = 81.88 \text{ plf}$$

$$v_{T_s} := \frac{V_{diaphT_{EL}}}{L_L} = 94.64 \text{ plf}$$

6" Nailing

$$Check_w := \text{if } v_{T_w} \leq v_{w6} = \text{"OK"}$$

"OK"

else

"NG!!"

$$Check_s := \text{if } v_{T_s} \leq v_{s6} = \text{"OK"}$$

"OK"

else

"NG!!"

**Use 15/32 APA Shtg w/ 10d nails @ 6" o.c. @ panel edges, 12" o.c. @ interior supports. Provide blocking @ panel edges.**



**Shear Wall Analysis - Upper Floor to Roof (ref. ANSI/AF+PA SDPWS -2021)****SW1 WIND IN - PLANE SHEAR**

$$h_t := 9 \text{ ft}$$

Wall height

$$L_s := 15 \text{ ft} + 2.67 \text{ ft}$$

Total shear wall length

$$SDL_{rf} = 12 \text{ psf}$$

Dead load of roof

$$R := R_{Lrf\_1} = 3.13 \text{ kip}$$

Reaction at grid

$$w_{rf} := \frac{2 \text{ ft}}{2} + 2 \text{ ft} = 3 \text{ ft}$$

Tributary width of roof on wall

$$p_{ext} = 12 \text{ psf}$$

Dead load of exterior walls

$$w_s := 2.67 \text{ ft}$$

Shear wall length

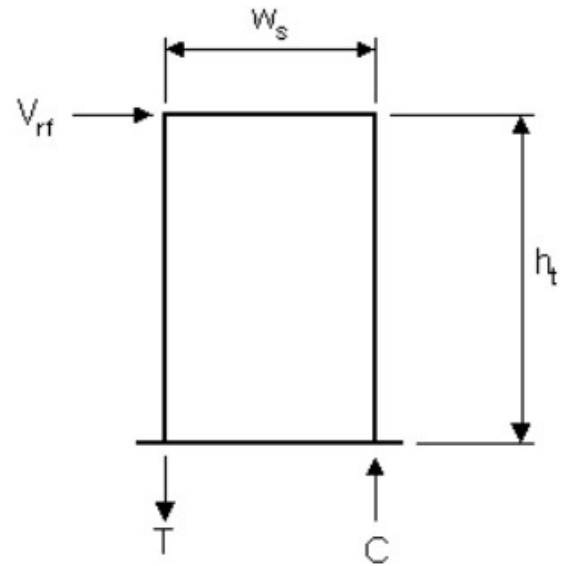
**Aspect Ratio (Blocked Shear Wall)**

$$\frac{h_t}{w_s} = 3.3708$$

$$check_{ratio} := \text{if } \frac{h_t}{w_s} > 3.5$$

$$check_{ratio} = \text{"OK"}$$

"NG"

else

"OK"

$$(WSP) := \text{if } \frac{h_t}{w_s} < 2.0$$

Aspect ratio factor

$$(WSP) = 0.8287$$

$$1.0$$

else

$$1.25 - 0.125 \cdot \frac{h_t}{w_s}$$

**Overtuning Forces**

$$V_{rf} := \left( R \cdot \frac{w_s}{L_s} \right) \cdot 0.6$$

Shear load at top of wall (ASD)

$$0.28 \text{ kip}$$

$$M_{ot} := V_{rf} \cdot h_t$$

Overtuning moment (ASD)

$$M_{ot} = 2.56 \text{ kip ft}$$

**Resisting Forces**

$$P_{rf} := SDL_{rf} \cdot w_{rf} \cdot w_s$$

Roof load

$$P_{rf} = 0.1 \text{ kip}$$

$$P_w := p_{ext} \cdot (h_t) \cdot w_s$$

Wall load

$$P_w = 0.29 \text{ kip}$$

$$M_{res} := \left( (P_{rf} + P_w) \cdot \frac{w_s}{2} \right) \cdot 0.6$$

Resisting moment (ASD)

$$M_{res} = 0.31 \text{ kip ft}$$

Plywood Shear ( ref. ANSI/AF+PA SDPWS)

$\Omega_{D_w} = 2.0$

(ref. section 4.3.3)

$n := 1$

sides

$$w_{all} := \frac{(WSP) \cdot w_{6_{8d}} \cdot n}{\Omega_{D_w}} = 302.46 \text{ plf}$$

**Single Sided 7/16" Plywood/OSB w/ 8d @ 6" O.C. Panel Edges @ 12" O.C. Interior Supports (ref. table 4.3A, 15/32 values)**

$$w_v := \frac{V_{rf}}{w_s} = 106.38 \text{ plf}$$

$$check_{wv} := \text{if } \frac{w_v}{w_{all}} > 1.0 \quad \text{ratio} := \frac{w_v}{w_{all}} = 0.35$$

 $check_{wv} = \text{"OK"}$  $\text{"NG"}$ 

else

 $\text{"OK"}$ Bottom Plate Nailing  $C_D := 1.6$ 

$t_{sp} := 1.5 \text{ in}$  Sill plate thickness

16d Nail

$sp_a := 6 \text{ in}$

Nail spacing

$Z_{11} := 103 \text{ lbf} \cdot C_D = 0.165 \text{ kip}$

Allowable load parallel to grain (ref. NDS table 12N)

$V_{sp} := w_v \cdot sp_a = 0.0532 \text{ kip}$  Shear load to each anchor

$check_a := \text{if } V_{sp} > Z_{11} \quad \text{ratio}_a := \frac{V_{sp}}{Z_{11}} = 0.32$

 $check_a = \text{"OK"}$  $\text{"NG"}$ 

else

 $\text{"OK"}$ **Use 16d Nails @ 6" o.c. staggered**Holdown

$T := \frac{M_{ot} - M_{res}}{w_s} = 0.84 \text{ kip}$

$check_T := \text{if } T > 0.15 \text{ kip}$   
 $\text{"HD REQ'D"}$   
else  
 $\text{"NOT REQ'D"}$

 $check_T = \text{"HD REQ'D"}$ 

$T_{all} := MST37 = 2705 \text{ lbf}$

Allowable tension load (ref. Simpson Load Tables)

$check_{HD} := \text{if } \frac{T}{T_{all}} > 1.0$

$\text{ratio} := \frac{T}{T_{all}} = 0.3113$

 $check_{HD} = \text{"OK"}$  $\text{"NG"}$ 

else

 $\text{"OK"}$ **Use Simpson MST37 or MSTC48B3 between floors**

SW1 SEISMIC IN - PLANE SHEAR

$$h_t := h_t = 9 \text{ ft}$$

Wall height

$$L_s := L_s = 17.67 \text{ ft}$$

Total shear wall length

$$SDL_{rf} = 12 \text{ psf}$$

Dead load of roof

$$R := R_{Lrf\_1\_EL} = 2.37 \text{ kip}$$

Reaction at grid

$$w_{rf} := w_{rf} = 3 \text{ ft}$$

Tributary width of roof on wall

$$p_{ext} = 12 \text{ psf}$$

Dead load of exterior walls

$$w_s := w_s = 2.67 \text{ ft}$$

Shear wall length

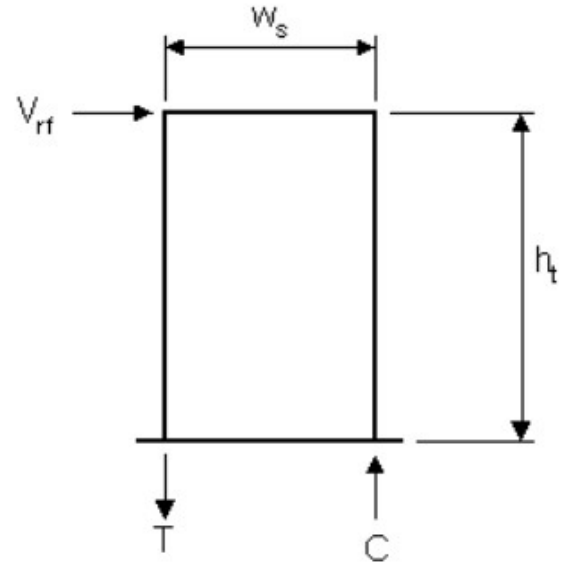
Aspect Ratio (Blocked Shear Wall)

$$\frac{h_t}{w_s} = 3.3708$$

$$check_{ratio} := \text{if } \frac{h_t}{w_s} > 3.5$$

$$check_{ratio} = \text{"OK"}$$

"NG"

else

"OK"

$$(WSP) := \text{if } \frac{h_t}{w_s} < 2.0$$

Aspect ratio factor

$$(WSP) = 0.8287$$

1.0

else

$$1.25 - 0.125 \cdot \frac{h_t}{w_s}$$

Overtuning Forces

$$V_{rf} := \left( R \cdot \frac{w_s}{L_s} \right) \cdot 0.7$$

Shear load at top of wall (ASD)

$$0.25 \text{ kip}$$

$$M_{ot} := V_{rf} \cdot h_t$$

Overtuning moment (ASD)

$$M_{ot} = 2.26 \text{ kip ft}$$

Resisting Forces

$$P_{rf} := SDL_{rf} \cdot w_{rf} \cdot w_s$$

Roof load

$$P_{rf} = 0.1 \text{ kip}$$

$$P_w := p_{ext} \cdot (h_t) \cdot w_s$$

Wall load

$$P_w = 0.29 \text{ kip}$$

$$M_{res} := \left( (P_{rf} + P_w) \cdot \frac{w_s}{2} \right) \cdot 0.6$$

Resisting moment (ASD)

$$M_{res} = 0.31 \text{ kip ft}$$

Plywood Shear ( ref. ANSI/AF+PA SDPWS)

$\Omega_{D_s} = 2.8$

(ref. section 4.3.3)

$n := 1$

sides

$$w_{all} := \frac{(WSP) \cdot w_{6\_8d} \cdot n}{\Omega_{D_s}} = 216 \text{ plf}$$

**Single Sided 7/16" Plywood/OSB w/ 8d @ 6" O.C. Panel Edges @ 12" O.C. Interior Supports (ref. table 4.3A, 15/32 values)**

$$w_v := \frac{V_{rf}}{w_s} = 93.86 \text{ plf}$$

$$check_{wv} := \text{if } \frac{w_v}{w_{all}} > 1.0 \text{ ratio} := \frac{w_v}{w_{all}} = 0.43$$

 $check_{wv} = \text{"OK"}$ **"NG"**

else

**"OK"**Bottom Plate Nailing  $C_D := 1.6$ 

$t_{sp} := 1.5 \text{ in}$  Sill plate thickness

16d Nail

$sp_a := 6 \text{ in}$

Nail spacing

$Z_{11} := 103 \text{ lbf} \cdot C_D = 0.165 \text{ kip}$

Allowable load parallel to grain (ref. NDS table 12N)

$V_{sp} := w_v \cdot sp_a = 0.0469 \text{ kip}$  Shear load to each anchor

$check_a := \text{if } V_{sp} > Z_{11}$

**"NG"**

else

**"OK"**

$ratio_a := \frac{V_{sp}}{Z_{11}} = 0.28$

 $check_a = \text{"OK"}$ **Use 16d Nails @ 6" o.c. staggered**Holdown

$T := \frac{M_{ot} - M_{res}}{w_s} = 0.73 \text{ kip}$

$check_T := \text{if } T > 0.150 \text{ kip}$

**"HD REQ'D"**

else

**"NOT REQ'D"** $check_T = \text{"HD REQ'D"}$ 

$T_{all} := MST37 = 2705 \text{ lbf}$

Allowable tension load (ref. Simpson Load Tables)

$check_{HD} := \text{if } \frac{T}{T_{all}} > 1.0$

**"NG"**

else

**"OK"**

$ratio := \frac{T}{T_{all}} = 0.2696$

 $check_{HD} = \text{"OK"}$ **Use Simpson MST37**Holdown w/ Overstrength Factor

$T := \frac{M_{ot} \cdot \Omega_{hd} - M_{res}}{w_s} = 2 \text{ kip}$

$\Omega_{hd} := \Omega_o - 0.5 = 2.5$

(ref. table 12.2-1, footnote'b')

$check_T := \text{if } T > 0.150 \text{ kip}$

**"HD REQ'D"**

else

**"NOT REQ'D"** $check_T = \text{"HD REQ'D"}$ 

$T_{all} := MSTC48B3 = 3975 \text{ lbf}$

Allowable tension load (ref. Simpson Load Tables)

$check_{HD} := \text{if } \frac{T}{T_{all}} > 1.0$

**"NG"**

else

**"OK"**

$ratio := \frac{T}{T_{all}} = 0.5022$

 $check_{HD} = \text{"OK"}$ **Use Simpson MSTC48B3**

SW2 WIND IN - PLANE SHEAR

$$h_t := 9 \text{ ft}$$

Wall height

$$L_s := 8.33 \text{ ft} + 2.67 \text{ ft}$$

Total shear wall length

$$SDL_{rf} = 12 \text{ psf}$$

Dead load of roof

$$R := R_{Lrf\_2} = 3.13 \text{ kip}$$

Reaction at grid

$$w_{rf} := \frac{2 \text{ ft}}{2} + 2 \text{ ft} = 3 \text{ ft}$$

Tributary width of roof on wall

$$p_{ext} = 12 \text{ psf}$$

Dead load of exterior walls

$$w_s := 2.67 \text{ ft}$$

Shear wall length

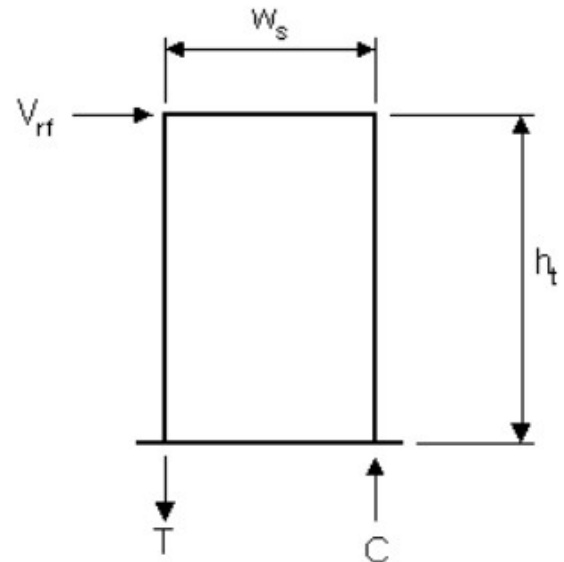
Aspect Ratio (Blocked Shear Wall)

$$\frac{h_t}{w_s} = 3.3708$$

$$check_{ratio} := \text{if } \frac{h_t}{w_s} > 3.5$$

$$check_{ratio} = \text{"OK"}$$

"NG"

else

"OK"

$$(WSP) := \text{if } \frac{h_t}{w_s} < 2.0$$

Aspect ratio factor

$$(WSP) = 0.8287$$

1.0

else

$$1.25 - 0.125 \cdot \frac{h_t}{w_s}$$

Overtuning Forces

$$V_{rf} := \left( R \cdot \frac{w_s}{L_s} \right) \cdot 0.6$$

Shear load at top of wall (ASD)

$$0.46 \text{ kip}$$

$$M_{ot} := V_{rf} \cdot h_t$$

Overtuning moment (ASD)

$$M_{ot} = 4.11 \text{ kip ft}$$

Resisting Forces

$$P_{rf} := SDL_{rf} \cdot w_{rf} \cdot w_s$$

Roof load

$$P_{rf} = 0.1 \text{ kip}$$

$$P_w := p_{ext} \cdot (h_t) \cdot w_s$$

Wall load

$$P_w = 0.29 \text{ kip}$$

$$M_{res} := \left( (P_{rf} + P_w) \cdot \frac{w_s}{2} \right) \cdot 0.6$$

Resisting moment (ASD)

$$M_{res} = 0.31 \text{ kip ft}$$

Plywood Shear ( ref. ANSI/AF+PA SDPWS)

$\Omega_{D_w} = 2.0$

(ref. section 4.3.3)

$n := 1$

sides

$$w_{all} := \frac{(WSP) \cdot w_{4\_8d} \cdot n}{\Omega_{D_w}} = 441.26 \text{ plf}$$

**Single Sided 7/16" Plywood/OSB w/ 8d @ 4" O.C. Panel  
Edges @ 12" O.C. Interior Supports (ref. table 4.3A, 15/32 values)**

$$w_v := \frac{V_{rf}}{w_s} = 170.88 \text{ plf}$$

$$check_{wv} := \text{if } \frac{w_v}{w_{all}} > 1.0 \text{ ratio} := \frac{w_v}{w_{all}} = 0.39$$

 $check_{wv} = \text{"OK"}$ **"NG"**

else

**"OK"**Bottom Plate Nailing  $C_D := 1.6$ 

$t_{sp} := 1.5 \text{ in}$  Sill plate thickness

16d Nail

$sp_a := 6 \text{ in}$

Nail spacing

$Z_{11} := 103 \text{ lbf} \cdot C_D = 0.165 \text{ kip}$

Allowable load parallel to grain (ref. NDS table 12N)

$V_{sp} := w_v \cdot sp_a = 0.0854 \text{ kip}$  Shear load to each anchor

$check_a := \text{if } V_{sp} > Z_{11}$

**"NG"**

else

**"OK"**

$ratio_a := \frac{V_{sp}}{Z_{11}} = 0.52$

 $check_a = \text{"OK"}$ **Use 16d Nails @ 6" o.c. staggered**Holdown

$T := \frac{M_{ot} - M_{res}}{w_s} = 1.42 \text{ kip}$

$check_T := \text{if } T > 0.15 \text{ kip}$

**"HD REQ'D"**

else

**"NOT REQ'D"** $check_T = \text{"HD REQ'D"}$ 

$T_{all} := MST37 = 2705 \text{ lbf}$

Allowable tension load (ref. Simpson Load Tables)

$check_{HD} := \text{if } \frac{T}{T_{all}} > 1.0$

**"NG"**

else

**"OK"**

$ratio := \frac{T}{T_{all}} = 0.5259$

 $check_{HD} = \text{"OK"}$ **Use Simpson MST37**

**SW2 SEISMIC IN - PLANE SHEAR**

$$h_t := h_t = 9 \text{ ft}$$

Wall height

$$L_s := L_s = 11 \text{ ft}$$

Total shear wall length

$$SDL_{rf} = 12 \text{ psf}$$

Dead load of roof

$$R := R_{Lrf\_2\_EL} = 2.37 \text{ kip}$$

Reaction at grid

$$w_{rf} := w_{rf} = 3 \text{ ft}$$

Tributary width of roof on wall

$$p_{ext} = 12 \text{ psf}$$

Dead load of exterior walls

$$w_s := w_s = 2.67 \text{ ft}$$

Shear wall length

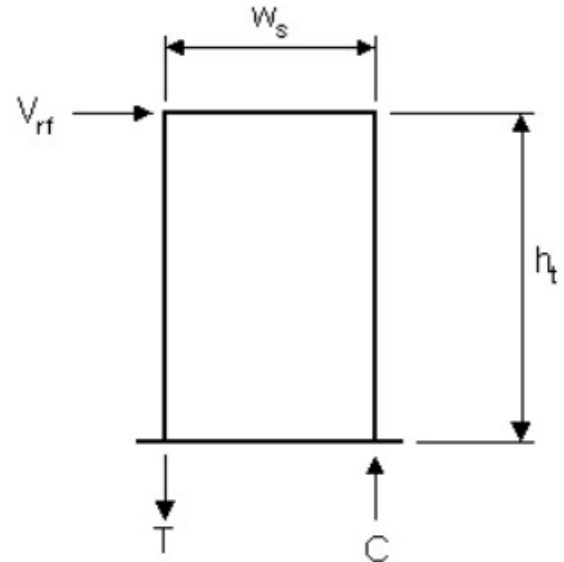

$$check_{ratio} = \text{"OK"}$$

**Aspect Ratio (Blocked Shear Wall)**

$$\frac{h_t}{w_s} = 3.3708$$

$$check_{ratio} := \text{if } \frac{h_t}{w_s} > 3.5$$

"NG"

else

"OK"

$$(WSP) := \text{if } \frac{h_t}{w_s} < 2.0$$

Aspect ratio factor

$$(WSP) = 0.8287$$

1.0

else

$$1.25 - 0.125 \cdot \frac{h_t}{w_s}$$

**Overturning Forces**

$$V_{rf} := \left( R \cdot \frac{w_s}{L_s} \right) \cdot 0.7$$

Shear load at top of wall (ASD)

$$0.4 \text{ kip}$$

$$M_{ot} := V_{rf} \cdot h_t$$

Overturning moment (ASD)

$$M_{ot} = 3.62 \text{ kip ft}$$

**Resisting Forces**

$$P_{rf} := SDL_{rf} \cdot w_{rf} \cdot w_s$$

Roof load

$$P_{rf} = 0.1 \text{ kip}$$

$$P_w := p_{ext} \cdot (h_t) \cdot w_s$$

Wall load

$$P_w = 0.29 \text{ kip}$$

$$M_{res} := \left( (P_{rf} + P_w) \cdot \frac{w_s}{2} \right) \cdot 0.6$$

Resisting moment (ASD)

$$M_{res} = 0.31 \text{ kip ft}$$

Plywood Shear ( ref. ANSI/AF+PA SDPWS)

$\Omega_{D_s} = 2.8$

(ref. section 4.3.3)

$n := 1$

sides

$$w_{all} := \frac{(WSP) \cdot w_{4-8d} \cdot n}{\Omega_{D_s}} = 315.2 \text{ plf}$$

**Single Sided 7/16" Plywood/OSB w/ 8d @ 4" O.C. Panel Edges @ 12" O.C. Interior Supports (ref. table 4.3A, 15/32 values)**

$$w_v := \frac{V_{rf}}{w_s} = 150.77 \text{ plf}$$

$$check_{wv} := \text{if } \frac{w_v}{w_{all}} > 1.0 \quad \text{ratio} := \frac{w_v}{w_{all}} = 0.48$$

 $check_{wv} = \text{"OK"}$ 

"NG"  
else  
"OK"

Bottom Plate Nailing  $C_D := 1.6$ 

$t_{sp} := 1.5 \text{ in}$  Sill plate thickness

16d Nail

$sp_a := 6 \text{ in}$

Nail spacing

$Z_{11} := 103 \text{ lbf} \cdot C_D = 0.165 \text{ kip}$

Allowable load parallel to grain (ref. NDS table 12N)

$V_{sp} := w_v \cdot sp_a = 0.0754 \text{ kip}$  Shear load to each anchor

$$check_a := \text{if } V_{sp} > Z_{11} \quad \text{ratio}_a := \frac{V_{sp}}{Z_{11}} = 0.46$$

 $check_a = \text{"OK"}$ 

"NG"  
else  
"OK"

**Use 16d Nails @ 6" o.c. staggered**Holdown

$$T := \frac{M_{ot} - M_{res}}{w_s} = 1.24 \text{ kip}$$

$$check_T := \text{if } T > 0.150 \text{ kip}$$

"HD REQ'D"  
else  
"NOT REQ'D"

 $check_T = \text{"HD REQ'D"}$ 

$T_{all} := MST37 = 2705 \text{ lbf}$

Allowable tension load (ref. Simpson Load Tables)

$$check_{HD} := \text{if } \frac{T}{T_{all}} > 1.0$$

"NG"  
else  
"OK"

$$\text{ratio} := \frac{T}{T_{all}} = 0.459$$

 $check_{HD} = \text{"OK"}$ **Use Simpson MST37**Holdown w/ Overstrength Factor

$\Omega_{hd} := \Omega_o - 0.5 = 2.5$

(ref. table 12.2-1, footnote'b')

$$T := \frac{M_{ot} \cdot \Omega_{hd} - M_{res}}{w_s} = 3.28 \text{ kip}$$

$$check_T := \text{if } T > 0.150 \text{ kip}$$

"HD REQ'D"  
else  
"NOT REQ'D"

 $check_T = \text{"HD REQ'D"}$ 

$T_{all} := 2 \cdot MSTC48B3 = 7950 \text{ lbf}$

Allowable tension load (ref. Simpson Load Tables)

$$check_{HD} := \text{if } \frac{T}{T_{all}} > 1.0$$

"NG"  
else  
"OK"

 $check_{HD} = \text{"OK"}$ **Use Simpson (2)MSTC48B3**

SWA WIND IN - PLANE SHEAR

$$h_t := 9 \text{ ft}$$

Wall height

$$L_s := 2.75 \text{ ft} + 7.5 \text{ ft} + 10.5 \text{ ft} + 4 \text{ ft}$$

Total shear wall length

$$SDL_{rf} = 12 \text{ psf}$$

Dead load of roof

$$R := R_{Trf\_A} = 1.63 \text{ kip}$$

Reaction at grid

$$w_{rf} := \frac{24 \text{ ft}}{2} + 2 \text{ ft} = 14 \text{ ft}$$

Tributary width of roof on wall

$$p_{ext} = 12 \text{ psf}$$

Dead load of exterior walls

$$w_s := 2.75 \text{ ft}$$

Shear wall length

Aspect Ratio (Blocked Shear Wall)

$$\frac{h_t}{w_s} = 3.2727$$

$$check_{ratio} := \text{if } \frac{h_t}{w_s} > 3.5$$

$$check_{ratio} = \text{"OK"}$$

"NG"

else

"OK"

$$(WSP) := \text{if } \frac{h_t}{w_s} < 2.0$$

Aspect ratio factor

$$(WSP) = 0.8409$$

1.0

else

$$1.25 - 0.125 \cdot \frac{h_t}{w_s}$$

Overtuning Forces

$$V_{rf} := \left( R \cdot \frac{w_s}{L_s} \right) \cdot 0.6$$

Shear load at top of wall (ASD)

$$0.11 \text{ kip}$$

$$M_{ot} := V_{rf} \cdot h_t$$

Overtuning moment (ASD)

$$M_{ot} = 0.98 \text{ kip ft}$$

Resisting Forces

$$P_{rf} := SDL_{rf} \cdot w_{rf} \cdot w_s$$

Roof load

$$P_{rf} = 0.46 \text{ kip}$$

$$P_w := p_{ext} \cdot (h_t) \cdot w_s$$

Wall load

$$P_w = 0.3 \text{ kip}$$

$$M_{res} := \left( (P_{rf} + P_w) \cdot \frac{w_s}{2} \right) \cdot 0.6$$

Resisting moment (ASD)

$$M_{res} = 0.63 \text{ kip ft}$$

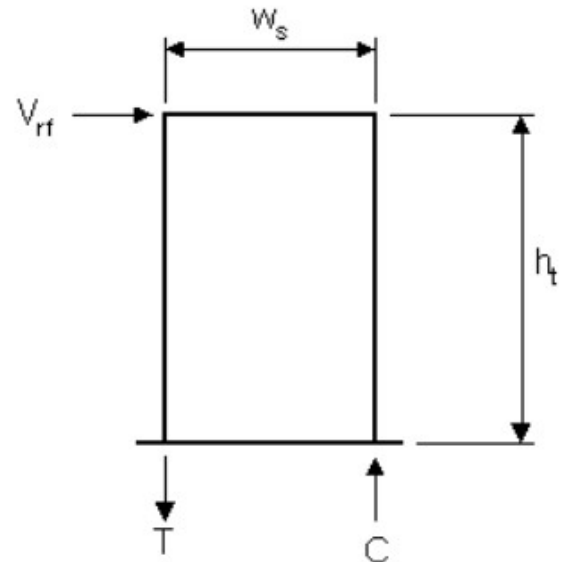

Plywood Shear (ref. ANSI/AF+PA SDPWS)

$\Omega_{D_w} = 2.0$

(ref. section 4.3.3)

$n := 1$

sides

$$w_{all} := \frac{(WSP) \cdot w_{6-8d} \cdot n}{\Omega_{D_w}} = 306.93 \text{ plf}$$

**Single Sided 7/16" Plywood/OSB w/ 8d @ 6" O.C. Panel Edges @ 12" O.C. Interior Supports (ref. table 4.3A, 15/32 values)**

$$w_v := \frac{V_{rf}}{w_s} = 39.63 \text{ plf}$$

$$check_{wv} := \text{if } \frac{w_v}{w_{all}} > 1.0 \quad \text{ratio} := \frac{w_v}{w_{all}} = 0.13$$

 $check_{wv} = \text{"OK"}$ 

"NG"

else

"OK"

Bottom Plate Nailing

$C_D := 1.6$

$t_{sp} := 1.5 \text{ in}$  Sill plate thickness

16d

Nail

$sp_a := 6 \text{ in}$

Nail spacing

$Z_{ll} := 103 \text{ lbf} \cdot C_D = 0.165 \text{ kip}$

Allowable load parallel to grain (ref. NDS table 12N)

$V_{sp} := w_v \cdot sp_a = 0.0198 \text{ kip}$  Shear load to each anchor

$Check_a := \text{if } V_{sp} > Z_{ll}$

"NG"

else

"OK"

$ratio_a := \frac{V_{sp}}{Z_{ll}} = 0.12$

 $Check_a = \text{"OK"}$ **Use 16d Nails @ 6" o.c. staggered**Holdown

$T := \frac{M_{ot} - M_{res}}{w_s} = 0.13 \text{ kip}$

$check_T := \text{if } T > 0.15 \text{ kip}$

"HD REQ'D"

else

"NOT REQ'D"

 $check_T = \text{"NOT REQ'D"}$

SWA SEISMIC IN - PLANE SHEAR

$$h_t := h_t = 9 \text{ ft}$$

Wall height

$$L_s := L_s = 24.75 \text{ ft}$$

Total shear wall length

$$SDL_{rf} = 12 \text{ psf}$$

Dead load of roof

$$R := R_{Trf\_A\_EL} = 2.37 \text{ kip}$$

Reaction at grid

$$w_{rf} := w_{rf} = 14 \text{ ft}$$

Tributary width of roof on wall

$$p_{ext} = 12 \text{ psf}$$

Dead load of exterior walls

$$w_s := w_s = 2.75 \text{ ft}$$

Shear wall length

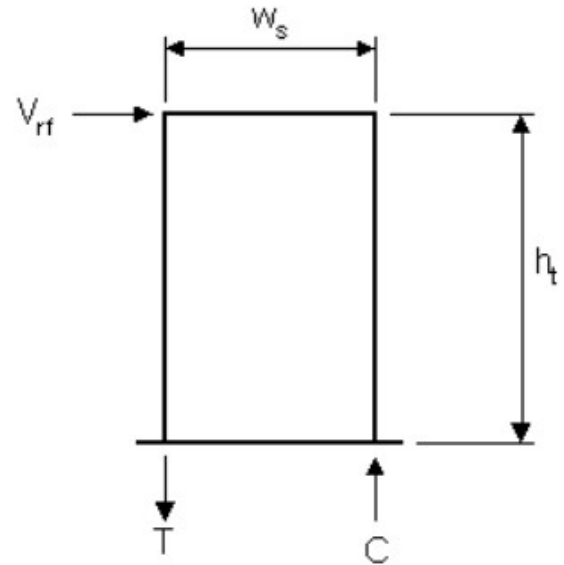

$$check_{ratio} = \text{"OK"}$$

Aspect Ratio (Blocked Shear Wall)

$$\frac{h_t}{w_s} = 3.2727$$

$$check_{ratio} := \text{if } \frac{h_t}{w_s} > 3.5$$

"NG"

else

"OK"

$$(WSP) := \text{if } \frac{h_t}{w_s} < 2.0$$

Aspect ratio factor

$$(WSP) = 0.8409$$

$$1.0$$

else

$$1.25 - 0.125 \cdot \frac{h_t}{w_s}$$

Overtuning Forces

$$V_{rf} := \left( R \cdot \frac{w_s}{L_s} \right) \cdot 0.7$$

Shear load at top of wall (ASD)

$$0.18 \text{ kip}$$

$$M_{ot} := V_{rf} \cdot h_t$$

Overtuning moment (ASD)

$$M_{ot} = 1.66 \text{ kip ft}$$

Resisting Forces

$$P_{rf} := SDL_{rf} \cdot w_{rf} \cdot w_s$$

Roof load

$$P_{rf} = 0.46 \text{ kip}$$

$$P_w := p_{ext} \cdot (h_t) \cdot w_s$$

Wall load

$$P_w = 0.3 \text{ kip}$$

$$M_{res} := \left( (P_{rf} + P_w) \cdot \frac{w_s}{2} \right) \cdot 0.6$$

Resisting moment (ASD)

$$M_{res} = 0.63 \text{ kip ft}$$

Plywood Shear (ref. ANSI/AF+PA SDPWS)

$\Omega_{D_s} = 2.8$

(ref. section 4.3.3)

 $n := 1$  sides

$$w_{all} := \frac{(WSP) \cdot w_{6-8d} \cdot n}{\Omega_{D_s}} = 219.2 \text{ plf}$$

**Single Sided 7/16" Plywood/OSB w/ 8d @ 6" O.C. Panel  
Edges @ 12" O.C. Interior Supports (ref. table 4.3A, 15/32 values)**

$$w_v := \frac{V_{rf}}{w_s} = 67.01 \text{ plf}$$

$$check_{wv} := \text{if } \frac{w_v}{w_{all}} > 1.0 \text{ ratio} := \frac{w_v}{w_{all}} = 0.31$$

 $check_{wv} = \text{"OK"}$  $\text{"NG"}$ 

else

 $\text{"OK"}$ Bottom Plate Nailing  $C_D := 1.6$ 

$t_{sp} := 1.5 \text{ in}$  Sill plate thickness

16d Nail

$sp_a := 6 \text{ in}$

Nail spacing

$Z_{11} := 103 \text{ lbf} \cdot C_D = 0.165 \text{ kip}$  Allowable load parallel to grain (ref. NDS table 12N)

$V_{sp} := w_v \cdot sp_a = 0.0335 \text{ kip}$  Shear load to each anchor

$check_a := \text{if } V_{sp} > Z_{11} \text{ ratio}_a := \frac{V_{sp}}{Z_{11}} = 0.2$

 $check_a = \text{"OK"}$  $\text{"NG"}$ 

else

 $\text{"OK"}$ **Use 16d Nails @ 6" o.c. staggered**Holdown

$T := \frac{M_{ot} - M_{res}}{w_s} = 0.38 \text{ kip}$

$check_T := \text{if } T > 0.150 \text{ kip}$

 $\text{"HD REQ'D"}$ 

else

 $\text{"NOT REQ'D"}$  $check_T = \text{"HD REQ'D"}$ 

$T_{all} := MST37 = 2705 \text{ lbf}$

Allowable tension load (ref. Simpson Load Tables)

$check_{HD} := \text{if } \frac{T}{T_{all}} > 1.0$

 $check_{HD} = \text{"OK"}$  $\text{"NG"}$ 

else

 $\text{"OK"}$ **Use Simpson MST37**Holdown w/ Overstrength Factor

$\Omega_{hd} := \Omega_o - 0.5 = 2.5$

(ref. table 12.2-1, footnote'b')

$T := \frac{M_{ot} \cdot \Omega_{hd} - M_{res}}{w_s} = 1.28 \text{ kip}$

$check_T := \text{if } T > 0.150 \text{ kip}$

 $\text{"HD REQ'D"}$ 

else

 $\text{"NOT REQ'D"}$  $check_T = \text{"HD REQ'D"}$ 

$T_{all} := MSTC48B3 = 3975 \text{ lbf}$

Allowable tension load (ref. Simpson Load Tables)

$check_{HD} := \text{if } \frac{T}{T_{all}} > 1.0$

 $check_{HD} = \text{"OK"}$  $\text{"NG"}$ 

else

 $\text{"OK"}$ **Use Simpson MSTC48B3**

SWB WIND IN - PLANE SHEAR

$$h_t := 9 \text{ ft}$$

Wall height

$$L_s := 18.5 \text{ ft} + 4.75 \text{ ft} + 9.5 \text{ ft}$$

Total shear wall length

$$SDL_{rf} = 12 \text{ psf}$$

Dead load of roof

$$R := R_{Trf\_B} = 1.63 \text{ kip}$$

Reaction at grid

$$w_{rf} := \frac{24 \text{ ft}}{2} + 2 \text{ ft} = 14 \text{ ft}$$

Tributary width of roof on wall

$$p_{ext} = 12 \text{ psf}$$

Dead load of exterior walls

$$w_s := 4.5 \text{ ft}$$

Shear wall length

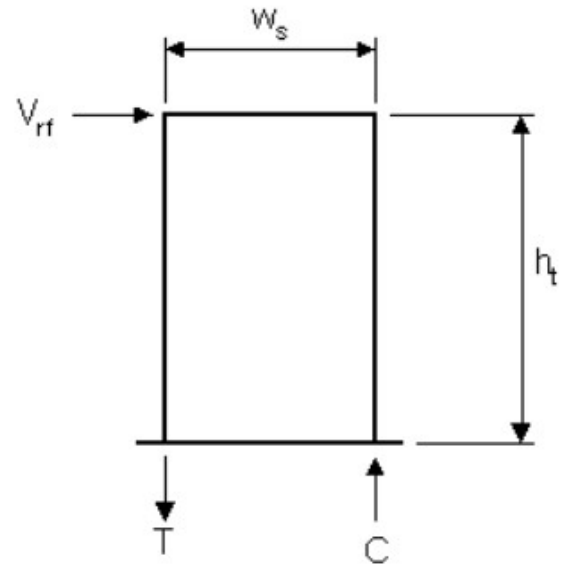

$$check_{ratio} = \text{"OK"}$$

Aspect Ratio (Blocked Shear Wall)

$$\frac{h_t}{w_s} = 2$$

$$check_{ratio} := \text{if } \frac{h_t}{w_s} > 3.5$$

"NG"

else

"OK"

$$(WSP) := \text{if } \frac{h_t}{w_s} < 2.0$$

Aspect ratio factor

$$(WSP) = 1$$

$$1.0$$

else

$$1.25 - 0.125 \cdot \frac{h_t}{w_s}$$

Overtuning Forces

$$V_{rf} := \left( R \cdot \frac{w_s}{L_s} \right) \cdot 0.6$$

Shear load at top of wall (ASD)

$$0.13 \text{ kip}$$

$$M_{ot} := V_{rf} \cdot h_t$$

Overtuning moment (ASD)

$$M_{ot} = 1.21 \text{ kip ft}$$

Resisting Forces

$$P_{rf} := SDL_{rf} \cdot w_{rf} \cdot w_s$$

Roof load

$$P_{rf} = 0.76 \text{ kip}$$

$$P_w := p_{ext} \cdot (h_t) \cdot w_s$$

Wall load

$$P_w = 0.49 \text{ kip}$$

$$M_{res} := \left( (P_{rf} + P_w) \cdot \frac{w_s}{2} \right) \cdot 0.6$$

Resisting moment (ASD)

$$M_{res} = 1.68 \text{ kip ft}$$

Plywood Shear ( ref. ANSI/AF+PA SDPWS)

$\Omega_{D_w} = 2.0$

(ref. section 4.3.3)

$n := 1$

sides

$$w_{all} := \frac{(WSP) \cdot w_{6\_8d} \cdot n}{\Omega_{D_w}} = 365 \text{ plf}$$

**Single Sided 7/16" Plywood/OSB w/ 8d @ 6" O.C. Panel  
Edges @ 12" O.C. Interior Supports (ref. table 4.3A, 15/32 values)**

$$w_v := \frac{V_{rf}}{w_s} = 29.95 \text{ plf}$$

$$check_{wv} := \text{if } \frac{w_v}{w_{all}} > 1.0 \quad \text{ratio} := \frac{w_v}{w_{all}} = 0.08$$

 $check_{wv} = \text{"OK"}$  $\text{"NG"}$ 

else

 $\text{"OK"}$ Bottom Plate Nailing  $C_D := 1.6$ 

$t_{sp} := 1.5 \text{ in}$  Sill plate thickness

16d Nail

$sp_a := 6 \text{ in}$

Nail spacing

$Z_{11} := 103 \text{ lbf} \cdot C_D = 0.165 \text{ kip}$

Allowable load parallel to grain (ref. NDS table 12N)

$V_{sp} := w_v \cdot sp_a = 0.015 \text{ kip}$  Shear load to each anchor

$check_a := \text{if } V_{sp} > Z_{11}$

 $\text{"NG"}$ 

else

 $\text{"OK"}$ 

$ratio_a := \frac{V_{sp}}{Z_{11}} = 0.09$

 $check_a = \text{"OK"}$ **Use 16d Nails @ 6" o.c. staggered**Holdown

$T := \frac{M_{ot} - M_{res}}{w_s} = -0.1 \text{ kip}$

$check_T := \text{if } T > 0.15 \text{ kip}$   
 $\text{"HD REQ'D"}$   
else  
 $\text{"NOT REQ'D"}$

 $check_T = \text{"NOT REQ'D"}$

SWB SEISMIC IN - PLANE SHEAR

$$h_t := h_t = 9 \text{ ft}$$

Wall height

$$L_s := L_s = 32.75 \text{ ft}$$

Total shear wall length

$$SDL_{rf} = 12 \text{ psf}$$

Dead load of roof

$$R := R_{Trf\_B\_EL} = 2.37 \text{ kip}$$

Reaction at grid

$$w_{rf} := w_{rf} = 14 \text{ ft}$$

Tributary width of roof on wall

$$p_{ext} = 12 \text{ psf}$$

Dead load of exterior walls

$$w_s := w_s = 4.5 \text{ ft}$$

Shear wall length

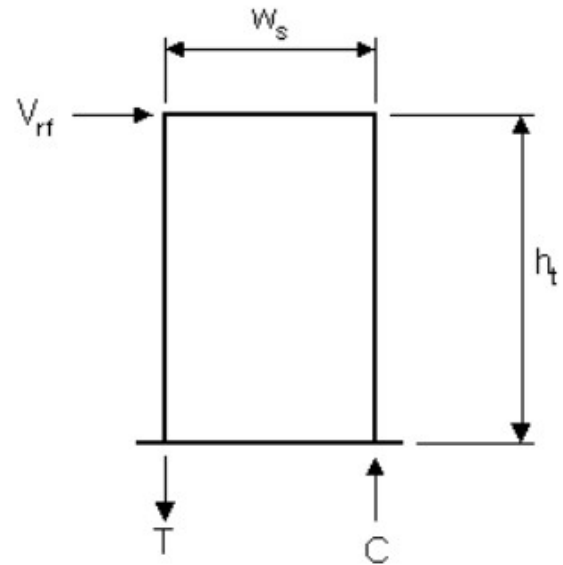
Aspect Ratio (Blocked Shear Wall)

$$\frac{h_t}{w_s} = 2$$

$$check_{ratio} := \text{if } \frac{h_t}{w_s} > 3.5$$

$$check_{ratio} = \text{"OK"}$$

"NG"

else

"OK"

$$(WSP) := \text{if } \frac{h_t}{w_s} < 2.0$$

Aspect ratio factor

$$(WSP) = 1$$

$$1.0$$

else

$$1.25 - 0.125 \cdot \frac{h_t}{w_s}$$

Overtuning Forces

$$V_{rf} := \left( R \cdot \frac{w_s}{L_s} \right) \cdot 0.7$$

Shear load at top of wall (ASD)

$$0.23 \text{ kip}$$

$$M_{ot} := V_{rf} \cdot h_t$$

Overtuning moment (ASD)

$$M_{ot} = 2.05 \text{ kip ft}$$

Resisting Forces

$$P_{rf} := SDL_{rf} \cdot w_{rf} \cdot w_s$$

Roof load

$$P_{rf} = 0.76 \text{ kip}$$

$$P_w := p_{ext} \cdot (h_t) \cdot w_s$$

Wall load

$$P_w = 0.49 \text{ kip}$$

$$M_{res} := \left( (P_{rf} + P_w) \cdot \frac{w_s}{2} \right) \cdot 0.6$$

Resisting moment (ASD)

$$M_{res} = 1.68 \text{ kip ft}$$

Plywood Shear ( ref. ANSI/AF+PA SDPWS)

$\Omega_{D_s} = 2.8$

(ref. section 4.3.3)

$n := 1$

sides

$$w_{all} := \frac{(WSP) \cdot w_{6\_8d} \cdot n}{\Omega_{D_s}} = 260.7 \text{ plf}$$

**Single Sided 7/16" Plywood/OSB w/ 8d @ 6" O.C. Panel Edges @ 12" O.C. Interior Supports (ref. table 4.3A, 15/32 values)**

$$w_v := \frac{V_{rf}}{W_s} = 50.64 \text{ plf}$$

$$check_{wv} := \text{if } \frac{w_v}{w_{all}} > 1.0 \text{ ratio} := \frac{w_v}{w_{all}} = 0.19$$

 $check_{wv} = \text{"OK"}$  $\text{"NG"}$ 

else

 $\text{"OK"}$ Bottom Plate Nailing  $C_D := 1.6$ 

$t_{sp} := 1.5 \text{ in}$  Sill plate thickness

16d

Nail

$sp_a := 6 \text{ in}$

Nail spacing

$Z_{11} := 103 \text{ lbf} \cdot C_D = 0.165 \text{ kip}$

Allowable load parallel to grain (ref. NDS table 12N)

$V_{sp} := w_v \cdot sp_a = 0.0253 \text{ kip}$  Shear load to each anchor

$check_a := \text{if } V_{sp} > Z_{11}$

 $\text{"NG"}$ 

else

 $\text{"OK"}$ 

$ratio_a := \frac{V_{sp}}{Z_{11}} = 0.15$

 $check_a = \text{"OK"}$ **Use 16d Nails @ 6" o.c. staggered**Holdown

$T := \frac{M_{ot} - M_{res}}{W_s} = 0.08 \text{ kip}$

$check_T := \text{if } T > 0.150 \text{ kip}$

 $\text{"HD REQ'D"}$ 

else

 $\text{"NOT REQ'D"}$  $check_T = \text{"NOT REQ'D"}$ 

$T_{all} := MST37 = 2705 \text{ lbf}$

Allowable tension load (ref. Simpson Load Tables)

$check_{HD} := \text{if } \frac{T}{T_{all}} > 1.0$

 $\text{"NG"}$ 

else

 $\text{"OK"}$ 

$ratio := \frac{T}{T_{all}} = 0.0307$

 $check_{HD} = \text{"OK"}$ **Use Simpson MST37**Holdown w/ Overstrength Factor

$\Omega_{hd} := \Omega_o - 0.5 = 2.5$

(ref. table 12.2-1, footnote'b')

$T := \frac{M_{ot} \cdot \Omega_{hd} - M_{res}}{W_s} = 0.77 \text{ kip}$

$check_T := \text{if } T > 0.150 \text{ kip}$

 $\text{"HD REQ'D"}$ 

else

 $\text{"NOT REQ'D"}$  $check_T = \text{"HD REQ'D"}$ 

$T_{all} := MSTC48B3 = 3975 \text{ lbf}$

Allowable tension load (ref. Simpson Load Tables)

$check_{HD} := \text{if } \frac{T}{T_{all}} > 1.0$

 $\text{"NG"}$ 

else

 $\text{"OK"}$  $check_{HD} = \text{"OK"}$ **Use Simpson MSTC48B3**

# HRS/ST/HTP/LSTA/LSTI/MST/MSTA/MSTC/MSTI

## Strap Ties

Straps are designed to transfer tension loads in a wide variety of applications.

**HRS** — **Heavy strap** designed for installation on the edge of 2x members. The HRS416Z installs with Strong-Drive® SDS Heavy-Duty Connector screws.

**HTP** — **Heavy tie plate** designed for installation on the side of 2x4 or larger members.

**LSTA and MSTA** — Designed for use on the edge of 2x members, with a nailing pattern that reduces the potential for splitting.

**LSTI and MSTI** — **Light and medium** straps that are suitable where pneumatic-nailing is necessary through diaphragm decking and wood chord open-web trusses.

**MST** — High-capacity strap that can be installed with either nails or bolts. Suitable for double 2x member connections or greater.

**MSTC** — High-capacity strap that utilizes a staggered nail pattern to help minimize wood splitting. Nail slots have been countersunk to provide a lower nail head profile.

**Finish:** Galvanized. Some products are available in stainless steel, ZMAX® coating or black powder coat (add PC to sku); contact Simpson Strong-Tie. See Corrosion Information, pp. 13–15.

**Installation:** Use all specified fasteners; see General Notes

**Options:** Special sizes can be made to order; contact Simpson Strong-Tie

**Codes:** See p. 12 for Code Reference Key Chart

MSTC and RPS meet code requirements for reinforcing cut members (16 gauge) at top plate and RPS at sill plate.

International Residential Code® — 2012/2015/2018 R602.6.1

International Building Code® — 2012/2015/2018 2308.9.8

(For RPS, refer to p. 303.)

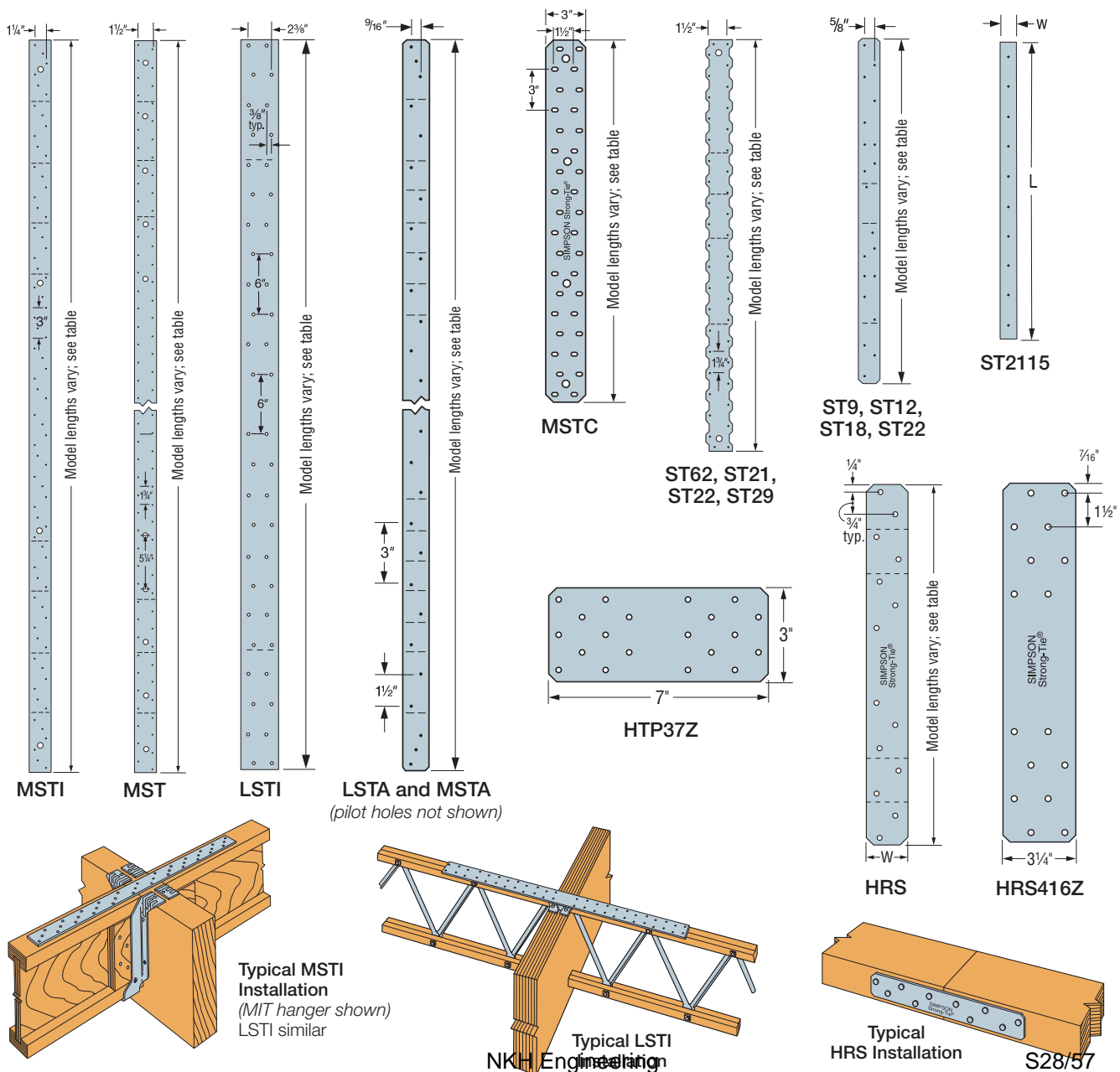

# MST/MSTA/MSTC

## Strap Ties (cont.)

**Codes:** See p. 12 for Code Reference Key Chart

These products are available with additional corrosion protection. For more information, see p. 15.

**SD** Many of these products are approved for installation with Strong-Drive® SD Connector screws. See pp. 335–337 for more information.

### Floor to Floor Span Table

Model No.	Clear Span (in.)	Fasteners (Total) (in.)	Allowable Tension Loads (DF/SP)	Allowable Tension Loads (SPF/HF)
			(160)	(160)
MSTA49	18	(26) 0.148 x 2½	2,020	2,020
	16	(26) 0.148 x 2½	2,020	2,020
MSTC28	18	(12) 0.148 x 3¼	1,150	995
	16	(16) 0.148 x 3¼	1,535	1,330
MSTC40	24	(20) 0.148 x 3¼	1,920	1,660
	18	(28) 0.148 x 3¼	2,690	2,325
	16	(32) 0.148 x 3¼	3,070	2,655
MSTC52	24	(36) 0.148 x 3¼	3,455	2,990
	18	(44) 0.148 x 3¼	4,225	3,650
	16	(48) 0.148 x 3¼	4,610	3,985
MSTC66	30	(48) 0.148 x 3¼	4,775	4,130
	24	(54) 0.148 x 3¼	5,375	4,645
	18	(64) 0.148 x 3¼	5,850	5,505
MSTC78	30	(64) 0.148 x 3¼	5,850	5,505
	24	(72) 0.148 x 3¼	5,850	5,850
	18	(76) 0.148 x 3¼	5,850	5,850
MST37	24	(14) 0.162 x 2½	1,720	1,500
	18	(20) 0.162 x 2½	2,460	2,140
	16	(22) 0.162 x 2½	2,705	2,355
MST48	24	(26) 0.162 x 2½	3,210	2,780
	18	(32) 0.162 x 2½	3,950	3,425
	16	(34) 0.162 x 2½	4,200	3,640
MST60	30	(34) 0.162 x 2½	4,605	3,995
	24	(40) 0.162 x 2½	5,240	4,700
	18	(46) 0.162 x 2½	6,235	5,405
MST72	30	(48) 0.162 x 2½	6,505	5,640
	24	(54) 0.162 x 2½	6,730	6,345
	18	(62) 0.162 x 2½	6,730	6,475

See footnotes below.

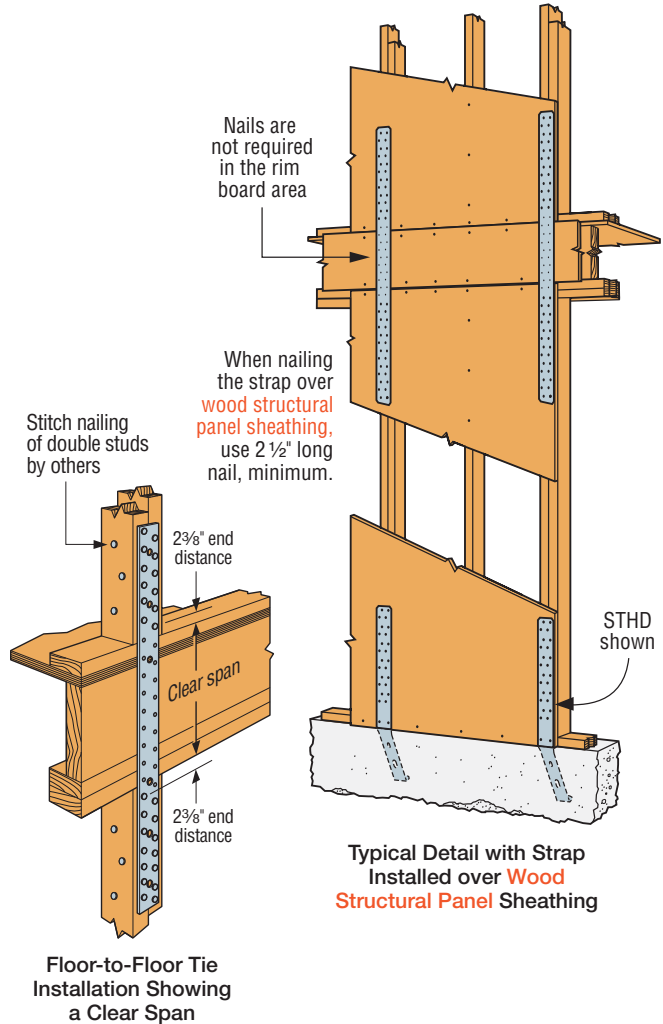

Straps and Ties

Model No.	Ga.	Dimensions (in.)		Fasteners (Total)			Allowable Tension Loads (DF/SP)		Allowable Tension Loads (SPF/HF)		Code Ref.
		W	L	Nails (in.)	Bolts		Nails (160)	Bolts (160)	Nails (160)	Bolts (160)	
					Qty.	Dia.					
MST27	12	2½	27	(30) 0.162 x 2½	4	½	3,700	2,165	3,210	2,000	IBC, FL, LA
MST37		2½	37½	(42) 0.162 x 2½	6	½	5,070	3,030	4,495	2,800	
MST48		2½	48	(50) 0.162 x 2½	8	½	5,310	3,675	5,190	3,395	
MST60	10	2½	60	(68) 0.162 x 2½	10	½	6,730	4,490	6,475	4,150	
MST72		2½	72	(68) 0.162 x 2½	10	½	6,730	4,490	6,475	4,150	

- See pp. 260–261 for Straps and Ties General Notes.
- Install bolts or nails as specified by Designer. Bolt and nail values may not be combined.
- Allowable bolt loads are based on parallel-to-grain loading and minimum member thickness: MST – 2½".
- Splitting may be a problem with installations on lumber smaller than 3½"; either fill every nail hole with 0.148" x 1½" nails or fill every other hole with 0.162" x 2½" nails. Reduce the allowable load based on the size and quantity of fasteners used.
- Fasteners:** Nail dimensions in the table are listed diameter by length. See pp. 21–22 for fastener information.

C-C-2019 © 2019 SIMPSON STRONG-TIE COMPANY INC.

# MSTC48B3/MSTC66B3Z

## Pre-Bent Straps

The MSTC48B3 and MSTC66B3Z are pre-bent straps designed to transfer tension load from an upper-story shearwall to a beam on the story below.

**Material:** 14 gauge

**Finish:** Galvanized; contact Simpson Strong-Tie

**Codes:** See p. 12 for Code Reference Key Chart

These products are available with additional corrosion protection. For more information, see p. 15.

Model No.	Min. Wood Beam Dimension (in.)		Fasteners (in.)			Allowable Tension Loads		Code Ref.
			Beam		Studs/Post	DF/SP (160)	SPF/HF (160)	
	Width (min.)	Depth (min.)	Face	Bottom				
MSTC48B3	3	9 1/4	(12) 0.148 x 3	(4)	(38) 0.148 x 3	3,975	3,900	IBC, FL, LA
MSTC66B3Z	3 1/2	11 1/4	(14) 0.148 x 3			4,490	4,490	

- Using fewer than 38 nails in the studs/post will reduce the allowable load of the connection. To calculate a reduced allowable load, use 199 lb. per nail for DF/SP or 172 lb. per nail for HF/SPF. Minimum length of extent of reduced nails may not be less than 21" as is shown in graphic.
- Nails in studs/post shall be installed symmetrically. Nails may be installed over the entire length of the strap in the studs/post.
- The minimum 3"-wide beam may be made up of two 2x members.
- MSTC48B3 and MSTC66B3Z installed over wood structural panel sheathing up to 1/2" thick achieve 0.85 of table loads.
- PSL beam may be used in lieu of a standard-dimension lumber beam with no load reductions.
- Multiply allowable loads by 1.85 to attain an allowable load for installations where two straps have been installed with a 1 1/2" clear space between straps.
- Structural composite lumber columns have sides that show either the wide face or the edges of the lumber strands/veneers known as the narrow face. Values in the tables reflect installation into the wide face. See technical bulletin T-C-SCLCLM at [strongtie.com](http://strongtie.com) for load reductions resulting from narrow-face installations.
- Fasteners:** Nail dimensions in the table are listed diameter by length. See pp. 21-22 for fastener information.

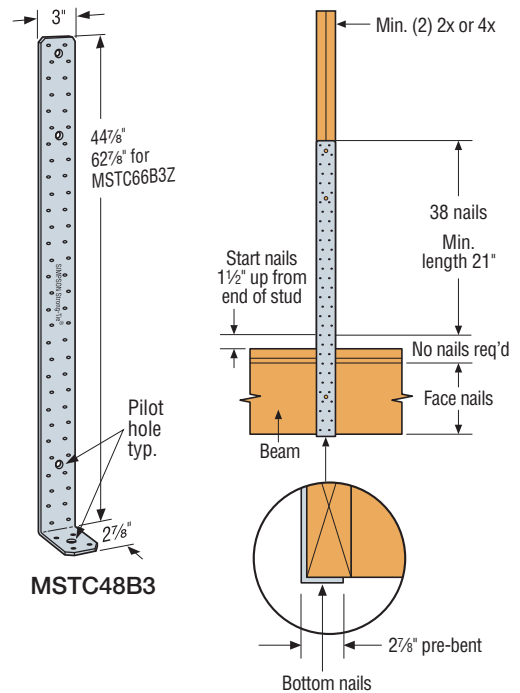

**MSTC48B3**  
Installation with  
No Rim Board

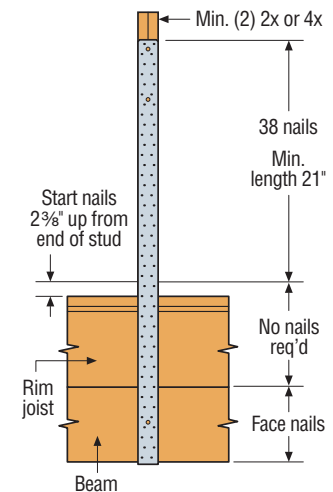

**MSTC66B3Z** Installation  
with Rim Board

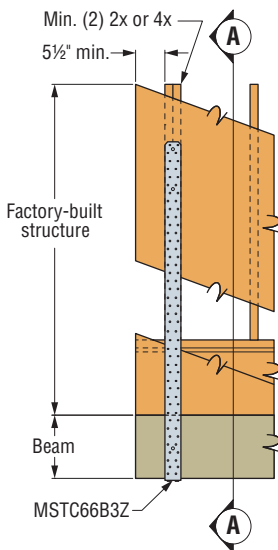

(2) MSTC66B3Z  
Installation

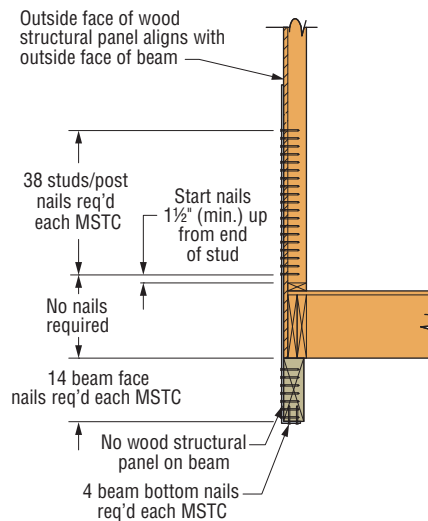

Section A-A

NKH Engineering

UPDATED 06/01/19

S30/57

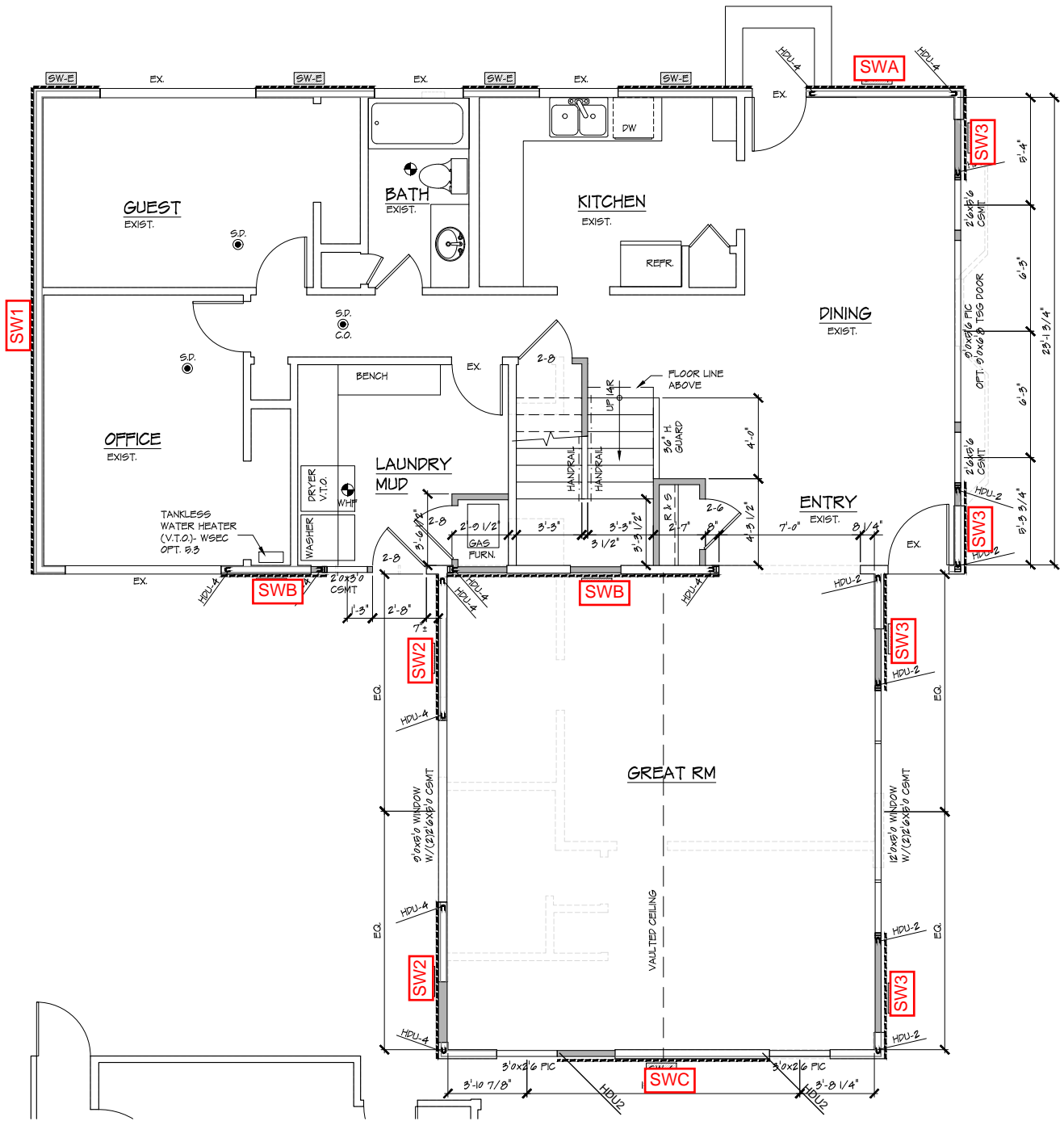

PROJECT: Rankin Addition

DESCRIPTION: Main Floor Shearwall Keyplan

BY: AKR NKH Engineering DATE: 11/5/2024

JOB #: 24-123 S31/57

☐—Main to Upper Floor Analysis

**Shear Wall Analysis - Main Upper Floor (ref. ANSI/AF+PA SDPWS -2021)****SW1 WIND IN - PLANE SHEAR**

$$h_t := 9 \text{ ft}$$

Wall height

$$L_s := 24 \text{ ft}$$

Total shear wall length

$$SDL_{rf} = 12 \text{ psf}$$

Dead load of roof

$$R := R_{Lup_1} = 5.18 \text{ kip}$$

Reaction at grid

$$w_{rf} := \frac{2 \text{ ft} + 1.33 \text{ ft}}{2} + 2 \text{ ft}$$

Tributary width of roof on wall

$$p_{ext} = 12 \text{ psf}$$

Dead load of exterior walls

$$w_s := 24 \text{ ft}$$

Shear wall length

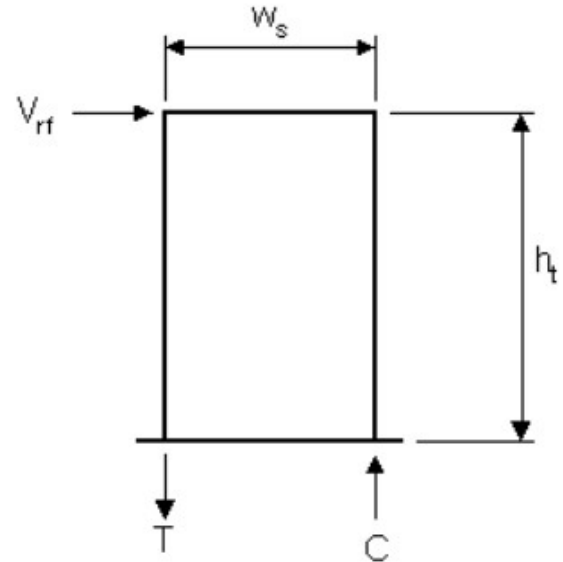

$$check_{ratio} = \text{"OK"}$$

**Aspect Ratio (Blocked Shear Wall)**

$$\frac{h_t}{w_s} = 0.375$$

$$check_{ratio} := \text{if } \frac{h_t}{w_s} > 3.5$$

"NG"

else

"OK"

$$(WSP) := \text{if } \frac{h_t}{w_s} < 2.0$$

Aspect ratio factor

$$(WSP) = 1$$

1.0  
else

$$1.25 - 0.125 \cdot \frac{h_t}{w_s}$$

**Overtuning Forces**

$$V_{rf} := \left( R \cdot \frac{w_s}{L_s} \right) \cdot 0.6$$

Shear load at top of wall (ASD)

$$3.11 \text{ kip}$$

$$M_{ot} := V_{rf} \cdot h_t$$

Overtuning moment (ASD)

$$M_{ot} = 27.98 \text{ kip ft}$$

**Resisting Forces**

$$P_{rf} := SDL_{rf} \cdot w_{rf} \cdot w_s$$

Roof load

$$P_{rf} = 1.06 \text{ kip}$$

$$P_w := p_{ext} \cdot (2 \cdot h_t) \cdot w_s$$

Wall load

$$P_w = 5.18 \text{ kip}$$

$$M_{res} := \left( (P_{rf} + P_w) \cdot \frac{w_s}{2} \right) \cdot 0.6$$

Resisting moment (ASD)

$$M_{res} = 44.92 \text{ kip ft}$$

Plywood Shear (ref. ANSI/AF+PA SDPWS)

$\Omega_{D_w} = 2.0$

(ref. section 4.3.3)

$n := 1$

sides

$$w_{all} := \frac{(WSP) \cdot (w_{hsl} + w_{gyp}) \cdot n}{\Omega_{D_w}} = 195 \text{ plf}$$

**Horizontal Ship Lap Exterior w/ Gyp Interior (SDPWS Table 4.3C + D)**

$$w_v := \frac{V_{rf}}{w_s} = 129.53 \text{ plf}$$

$$check_{wv} := \text{if } \frac{w_v}{w_{all}} > 1.0 \text{ ratio} := \frac{w_v}{w_{all}} = 0.66$$

 $check_{wv} = \text{"OK"}$  $\text{"NG"}$ 

else

 $\text{"OK"}$ Sill Plate Anchorage  $C_D := 1.6$ 

$t_{sp} := 1.5 \text{ in}$  Sill plate thickness

$dia_a := 0.625 \text{ in}$  Anchor dia

$sp_a := 48 \text{ in}$

Anchor spacing

$Z_{11} := v_{A.5.2x} \cdot C_D = 1.04 \text{ kip}$

Allowable load parallel to grain (ref. NDS table 12E)

$V_{sp} := w_v \cdot sp_a = 0.5181 \text{ kip}$  Shear load to each anchor

$Check_a := \text{if } V_{sp} > Z_{11}$

 $\text{"NG"}$ 

else

 $\text{"OK"}$ 

$ratio_a := \frac{V_{sp}}{Z_{11}} = 0.4982$

 $Check_a = \text{"OK"}$ **Existing 1/2" Dia. Anchor @ 48" o.c. OK**Holdown

$\Omega_{HD_{ecc}} := 0.92$

HD eccentricity reduction factor (Table 4.3A, footnote 10)

$T := \frac{M_{ot} - M_{res}}{w_s} = -0.7061 \text{ kip}$

$check_T := \text{if } T > 0.25 \text{ kip}$

 $\text{"HD REQ'D"}$ 

else

 $\text{"NOT REQ'D"}$  $check_T = \text{"NOT REQ'D"}$

SW1 SEISMIC IN - PLANE SHEAR

$$h_t := 9 \text{ ft}$$

Wall height

$$L_s := L_s = 24 \text{ ft}$$

Total shear wall length

$$SDL_{rf} = 12 \text{ psf}$$

Dead load of roof

$$R := R_{Lup\_1\_EL} = 4.09 \text{ kip}$$

Reaction at grid

$$w_{rf} := w_{rf} = 3.665 \text{ ft}$$

Tributary width of roof on wall

$$p_{ext} = 12 \text{ psf}$$

Dead load of exterior walls

$$w_s := w_s = 24 \text{ ft}$$

Shear wall length

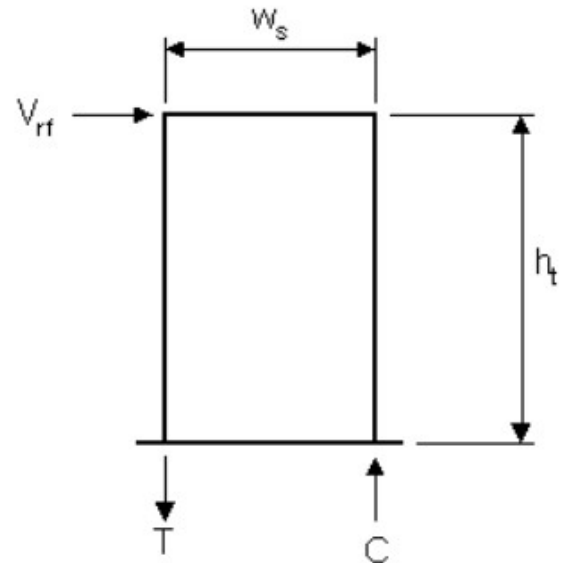

$$check_{ratio} = \text{"OK"}$$

Aspect Ratio (Blocked Shear Wall)

$$\frac{h_t}{w_s} = 0.375$$

$$check_{ratio} := \text{if } \frac{h_t}{w_s} > 3.5$$

"NG"

else

"OK"

$$(WSP) := \text{if } \frac{h_t}{w_s} < 2.0$$

Aspect ratio factor

$$(WSP) = 1$$

$$1.0$$

else

$$1.25 - 0.125 \cdot \frac{h_t}{w_s}$$

Overtuning Forces

$$V_{rf} := \left( R \cdot \frac{w_s}{L_s} \right) \cdot 0.7$$

Shear load at top of wall (ASD)

$$2.86 \text{ kip}$$

$$M_{ot} := V_{rf} \cdot h_t$$

Overtuning moment (ASD)

$$M_{ot} = 25.74 \text{ kip ft}$$

Resisting Forces

$$P_{rf} := SDL_{rf} \cdot w_{rf} \cdot w_s$$

Roof load

$$P_{rf} = 1.06 \text{ kip}$$

$$P_w := p_{ext} \cdot (2 \cdot h_t) \cdot w_s$$

Wall load

$$P_w = 5.18 \text{ kip}$$

$$M_{res} := \left( (P_{rf} + P_w) \cdot \frac{w_s}{2} \right) \cdot 0.6$$

Resisting moment (ASD)

$$M_{res} = 44.92 \text{ kip ft}$$

Plywood Shear (ref. ANSI/AF+PA SDPWS)

$\Omega_{D_s} = 2.8$

(ref. section 4.3.3)

$n := 1$

sides

$$w_{all} := \frac{(WSP) \cdot (w_{hsl} + w_{gyp}) \cdot n}{\Omega_{D_s}} = 139.29 \text{ plf}$$

**Horizontal Ship Lap Exterior w/ Gyp Interior (SDPWS Table 4.3C + D)**

$$w_v := \frac{V_{rf}}{w_s} = 119.18 \text{ plf}$$

$$check_{wv} := \text{if } \frac{w_v}{w_{all}} > 1.10$$

$$ratio := \frac{w_v}{w_{all}} = 0.86$$

 $check_{wv} = \text{"OK"}$ 

"NG"

else

"OK"

Sill Plate Anchorage

$C_D := 1.6$

$t_{sp} := 1.5 \text{ in}$  Sill plate thickness

$dia_a := 0.625 \text{ in}$  Anchor dia

$sp_a := 48 \text{ in}$

Anchor spacing

$Z_{11} := v_{A.5.2x} \cdot C_D = 1.04 \text{ kip}$

Allowable load parallel to grain (ref. NDS table 12E)

$V_{sp} := w_v \cdot sp_a = 0.4767 \text{ kip}$  Shear load to each anchor

$check_a := \text{if } V_{sp} > Z_{11}$

"NG"

else

"OK"

$ratio_a := \frac{V_{sp}}{Z_{11}} = 0.4584$

 $check_a = \text{"OK"}$ **Existing 1/2" Dia. Anchor @ 48" o.c. OK**Holdown

$\Omega_{HD_{ecc}} := 0.92$

HD eccentricity reduction factor (Table 4.3A, footnote 10)

$T := \frac{M_{ot} - M_{res}}{w_s} = -0.7992 \text{ kip}$

$check_T := \text{if } T > 0.25 \text{ kip}$

"HD REQ'D"

else

"NOT REQ'D"

 $check_T = \text{"NOT REQ'D"}$

SW2 WIND IN - PLANE SHEAR

$$h_t := 9 \text{ ft}$$

Wall height

$$L_s := 7.25 \text{ ft} + 7.25 \text{ ft}$$

Total shear wall length

$$SDL_{rf} = 12 \text{ psf}$$

Dead load of roof

$$R := R_{Lup\_2} = 4.71 \text{ kip}$$

Reaction at grid

$$w_{rf} := \frac{22 \text{ ft}}{2} + 2 \text{ ft}$$

Tributary width of roof on wall

$$p_{ext} = 12 \text{ psf}$$

Dead load of exterior walls

$$w_s := 7.25 \text{ ft}$$

Shear wall length

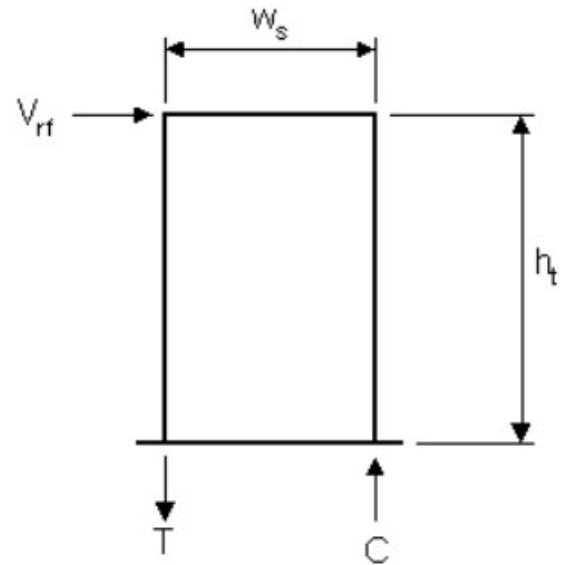
Aspect Ratio (Blocked Shear Wall)

$$\frac{h_t}{w_s} = 1.2414$$

$$check_{ratio} := \text{if } \frac{h_t}{w_s} > 3.5$$

"NG"

else

"OK"

$$check_{ratio} = \text{"OK"}$$

$$(WSP) := \text{if } \frac{h_t}{w_s} < 2.0$$

Aspect ratio factor

$$(WSP) = 1$$

$$1.0$$

else

$$1.25 - 0.125 \cdot \frac{h_t}{w_s}$$

Overtuning Forces

$$V_{rf} := \left( R \cdot \frac{w_s}{L_s} \right) \cdot 0.6$$

Shear load at top of wall (ASD)

$$1.41 \text{ kip}$$

$$M_{ot} := V_{rf} \cdot h_t$$

Overtuning moment (ASD)

$$M_{ot} = 12.72 \text{ kip ft}$$

Resisting Forces

$$P_{rf} := SDL_{rf} \cdot w_{rf} \cdot w_s$$

Roof load

$$P_{rf} = 1.13 \text{ kip}$$

$$P_w := p_{ext} \cdot (h_t) \cdot w_s$$

Wall load

$$P_w = 0.78 \text{ kip}$$

$$M_{res} := \left( (P_{rf} + P_w) \cdot \frac{w_s}{2} \right) \cdot 0.6$$

Resisting moment (ASD)

$$M_{res} = 4.16 \text{ kip ft}$$

Plywood Shear (ref. ANSI/AF+PA SDPWS)

$\Omega_{D_w} = 2.0$

(ref. section 4.3.3)

$n := 1$

sides

$$w_{all} := \frac{(WSP) \cdot w_{4\_8d} \cdot n}{\Omega_{D_w}} = 532.5 \text{ plf}$$

**Double Sided 7/16" Plywood/OSB w/ 8d @ 4" O.C. Panel  
Edges @ 12" O.C. Interior Supports (ref. table 4.3A, 15/32 values)**

$$w_v := \frac{V_{rf}}{w_s} = 194.95 \text{ plf}$$

$$check_{wv} := \text{if } \frac{w_v}{w_{all}} > 1.0 \text{ ratio} := \frac{w_v}{w_{all}} = 0.37$$

 $check_{wv} = \text{"OK"}$  $\text{"NG"}$ 

else

 $\text{"OK"}$ Sill Plate Anchorage  $C_D := 1.6$ 

$t_{sp} := 1.5 \text{ in}$  Sill plate thickness

$dia_a := 0.625 \text{ in}$  Anchor dia

$sp_a := 32 \text{ in}$

Anchor spacing

$Z_{ll} := 930 \text{ lbf} \cdot C_D = 1.488 \text{ kip}$  Allowable load parallel to grain (ref. NDS table 12E)

$V_{sp} := w_v \cdot sp_a = 0.5199 \text{ kip}$  Shear load to each anchor

$Check_a := \text{if } V_{sp} > Z_{ll} \text{ ratio}_a := \frac{V_{sp}}{Z_{ll}} = 0.3494$

 $Check_a = \text{"OK"}$  $\text{"NG"}$ 

else

 $\text{"OK"}$ **Use 5/8" Dia. Anchor @ 32" o.c. (6" min. embed)**Holdown

$\Omega_{HD\_ecc} := 0.92$

HD eccentricity reduction factor (Table 4.3A, footnote 10)

$T := \frac{M_{ot} - M_{res}}{w_s} = 1.1804 \text{ kip}$

$check_T := \text{if } T > 0.25 \text{ kip}$

 $check_T = \text{"HD REQ'D"}$  $\text{"HD REQ'D"}$ 

else

 $\text{"NOT REQ'D"}$ 

$T_{all} := HDU4 \cdot \Omega_{HD\_ecc} = 4.2 \text{ kip}$

Allowable tension load (ref. Simpson Load Tables)

$check_{HD} := \text{if } \frac{T}{T_{all}} > 1.0$

 $check_{HD} = \text{"OK"}$  $\text{"NG"}$ 

else

 $\text{"OK"}$ **Use Simpson HDU4 w/ 5/8" Dia anchor (12" embed into footing)**

SW2 SEISMIC IN - PLANE SHEAR

$$h_t := 10 \text{ ft}$$

Wall height

$$L_s := L_s = 14.5 \text{ ft}$$

Total shear wall length

$$SDL_{rf} = 12 \text{ psf}$$

Dead load of roof

$$R := R_{Lup\_2\_EL} = 3.95 \text{ kip}$$

Reaction at grid

$$w_{rf} := w_{rf} = 13 \text{ ft}$$

Tributary width of roof on wall

$$p_{ext} = 12 \text{ psf}$$

Dead load of exterior walls

$$w_s := w_s = 7.25 \text{ ft}$$

Shear wall length

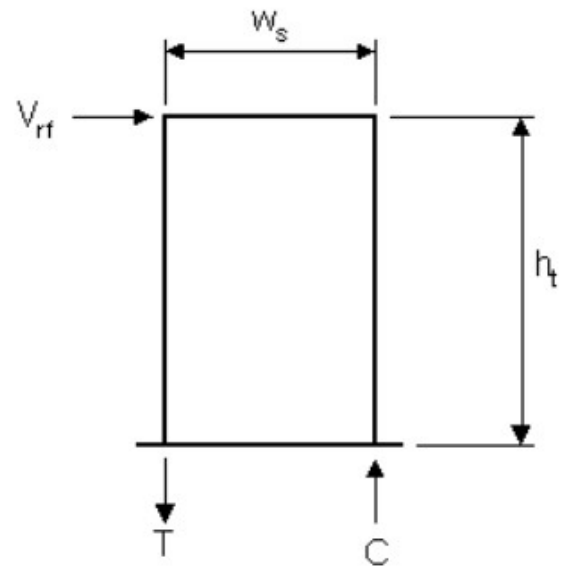

$$check_{ratio} = \text{"OK"}$$

Aspect Ratio (Blocked Shear Wall)

$$\frac{h_t}{w_s} = 1.3793$$

$$check_{ratio} := \text{if } \frac{h_t}{w_s} > 3.5$$

"NG"

else

"OK"

$$(WSP) := \text{if } \frac{h_t}{w_s} < 2.0$$

Aspect ratio factor

$$(WSP) = 1$$

1.0

else

$$1.25 - 0.125 \cdot \frac{h_t}{w_s}$$

Overtuning Forces

$$V_{rf} := \left( R \cdot \frac{w_s}{L_s} \right) \cdot 0.7$$

Shear load at top of wall (ASD)

$$1.38 \text{ kip}$$

$$M_{ot} := V_{rf} \cdot h_t$$

Overtuning moment (ASD)

$$M_{ot} = 13.82 \text{ kip ft}$$

Resisting Forces

$$P_{rf} := SDL_{rf} \cdot w_{rf} \cdot w_s$$

Roof load

$$P_{rf} = 1.13 \text{ kip}$$

$$P_w := p_{ext} \cdot (h_t) \cdot w_s$$

Wall load

$$P_w = 0.87 \text{ kip}$$

$$M_{res} := \left( (P_{rf} + P_w) \cdot \frac{w_s}{2} \right) \cdot 0.6$$

Resisting moment (ASD)

$$M_{res} = 4.35 \text{ kip ft}$$

Plywood Shear ( ref. ANSI/AF+PA SDPWS)

$\Omega_{D_s} = 2.8$

(ref. section 4.3.3)

$n := 1$

sides

$$w_{all} := \frac{(WSP) \cdot w_{4\_8d} \cdot n}{\Omega_{D_s}} = 380.36 \text{ plf}$$

**Single Sided 7/16" Plywood/OSB w/ 8d @ 3" O.C. Panel Edges @ 12" O.C. Interior Supports (ref. table 4.3A, 15/32 values)**

$$w_v := \frac{V_{rf}}{w_s} = 190.64 \text{ plf}$$

$$check_{wv} := \text{if } \frac{w_v}{w_{all}} > 1.0 \text{ ratio} := \frac{w_v}{w_{all}} = 0.50$$

 $check_{wv} = \text{"OK"}$  $\text{"NG"}$ 

else

 $\text{"OK"}$ Sill Plate Anchorage

$C_D := 1.6$

$t_{sp} := 1.5 \text{ in}$  Sill plate thickness

$dia_a := 0.625 \text{ in}$  Anchor dia

$sp_a := 32 \text{ in}$

Anchor spacing

$Z_{11} := 930 \text{ lbf} \cdot C_D = 1.488 \text{ kip}$

Allowable load parallel to grain (ref. NDS table 12E)

$V_{sp} := w_v \cdot sp_a = 0.5084 \text{ kip}$  Shear load to each anchor

$check_a := \text{if } V_{sp} > Z_{11}$

 $\text{"NG"}$ 

else

 $\text{"OK"}$ 

$ratio_a := \frac{V_{sp}}{Z_{11}} = 0.3417$

 $check_a = \text{"OK"}$ **Use 5/8" Dia. Anchor @ 32" o.c. (6" min. embed)**Holdown

$\Omega_{HD\_ecc} := 0.92$

HD eccentricity reduction factor (Table 4.3A, footnote 10)

$T := \frac{M_{ot} - M_{res}}{w_s} = 1.3061 \text{ kip}$

$check_T := \text{if } T > 0.25 \text{ kip}$   
 $\text{"HD REQ'D"}$   
else  
 $\text{"NOT REQ'D"}$

 $check_T = \text{"HD REQ'D"}$ 

$T_{all} := HDU4 \cdot \Omega_{HD\_ecc} = 4.2 \text{ kip}$

Allowable tension load (ref. Simpson Load Tables)

$check_{HD} := \text{if } \frac{T}{T_{all}} > 1.0$

 $\text{"NG"}$ 

else

 $\text{"OK"}$  $check_{HD} = \text{"OK"}$ **Use Simpson HDU4 w/ 5/8" Dia anchor (12" embed into footing)**

SW3 WIND IN - PLANE SHEAR

$$h_t := 9 \text{ ft}$$

Wall height

$$L_s := 4.5 \text{ ft} \cdot 2 + 5.5 \text{ ft} + 6 \text{ ft}$$

Total shear wall length

$$SDL_{rf} = 12 \text{ psf}$$

Dead load of roof

$$R := R_{Lup\_3} = 5.18 \text{ kip}$$

Reaction at grid

$$w_{rf} := \frac{2 \text{ ft} + 1.33 \text{ ft}}{2} + 2 \text{ ft}$$

Tributary width of roof on wall

$$p_{ext} = 12 \text{ psf}$$

Dead load of exterior walls

$$w_s := 4.5 \text{ ft}$$

Shear wall length

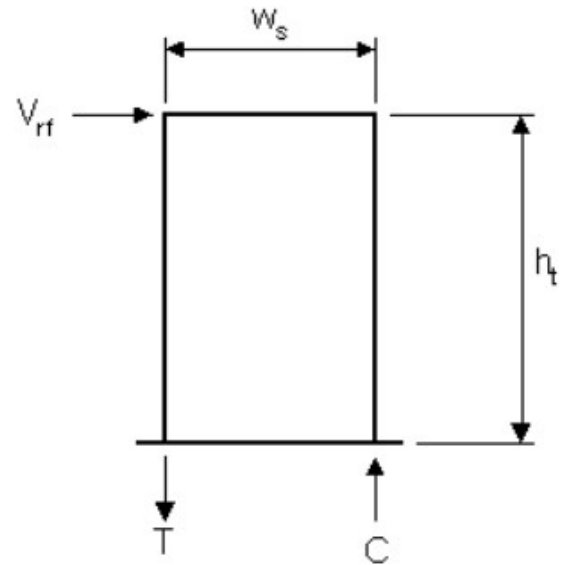

$$check_{ratio} = \text{"OK"}$$

Aspect Ratio (Blocked Shear Wall)

$$\frac{h_t}{w_s} = 2$$

$$check_{ratio} := \text{if } \frac{h_t}{w_s} > 3.5$$

"NG"

else

"OK"

$$(WSP) := \text{if } \frac{h_t}{w_s} < 2.0$$

Aspect ratio factor

$$(WSP) = 1$$

$$1.0$$

else

$$1.25 - 0.125 \cdot \frac{h_t}{w_s}$$

Overtuning Forces

$$V_{rf} := \left( R \cdot \frac{w_s}{L_s} \right) \cdot 0.6$$

Shear load at top of wall (ASD)

$$0.68 \text{ kip}$$

$$M_{ot} := V_{rf} \cdot h_t$$

Overtuning moment (ASD)

$$M_{ot} = 6.14 \text{ kip ft}$$

Resisting Forces

$$P_{rf} := SDL_{rf} \cdot w_{rf} \cdot w_s$$

Roof load

$$P_{rf} = 0.2 \text{ kip}$$

$$P_w := p_{ext} \cdot (2 \cdot h_t) \cdot w_s$$

Wall load

$$P_w = 0.97 \text{ kip}$$

$$M_{res} := \left( (P_{rf} + P_w) \cdot \frac{w_s}{2} \right) \cdot 0.6$$

Resisting moment (ASD)

$$M_{res} = 1.58 \text{ kip ft}$$

Plywood Shear ( ref. ANSI/AF+PA SDPWS)

$\Omega_{D_w} = 2.0$

(ref. section 4.3.3)

$n := 1$

sides

$$w_{all} := \frac{(WSP) \cdot w_{6\_8d} \cdot n}{\Omega_{D_w}} = 365 \text{ plf}$$

**Single Sided 7/16" Plywood/OSB w/ 8d @ 6" O.C. Panel Edges @ 12" O.C. Interior Supports (ref. table 4.3A, 15/32 values)**

$$w_v := \frac{V_{rf}}{w_s} = 151.65 \text{ plf}$$

$$check_{wv} := \text{if } \frac{w_v}{w_{all}} > 1.02 \text{ ratio} := \frac{w_v}{w_{all}} = 0.42$$

 $check_{wv} = \text{"OK"}$ 

"NG"

else

"OK"

Sill Plate Anchorage  $C_D := 1.6$ 

$t_{sp} := 1.5 \text{ in}$  Sill plate thickness

$dia_a := 0.625 \text{ in}$  Anchor dia

$sp_a := 48 \text{ in}$

Anchor spacing

$Z_{11} := 930 \text{ lbf} \cdot C_D = 1.488 \text{ kip}$

Allowable load parallel to grain (ref. NDS table 12E)

$V_{sp} := w_v \cdot sp_a = 0.6066 \text{ kip}$  Shear load to each anchor

$check_a := \text{if } V_{sp} > Z_{11}$

"NG"

else

"OK"

$ratio_a := \frac{V_{sp}}{Z_{11}} = 0.4077$

 $check_a = \text{"OK"}$ **Use 5/8" Dia. Anchor @ 48" o.c. (6" min. embed)**Holdown

$\Omega_{HD\_ecc} := 0.92$

HD eccentricity reduction factor (Table 4.3A, footnote 10)

$T := \frac{M_{ot} - M_{res}}{w_s} = 1.0139 \text{ kip}$

$check_T := \text{if } T > 0.25 \text{ kip}$

"HD REQ'D"

else

"NOT REQ'D"

 $check_T = \text{"HD REQ'D"}$ 

$T_{all} := HDU2 \cdot \Omega_{HD\_ecc} = 2.83 \text{ kip}$

Allowable tension load (ref. Simpson Load Tables)

$check_{HD} := \text{if } \frac{T}{T_{all}} > 1.0$

"NG"

else

"OK"

 $check_{HD} = \text{"OK"}$ **Use Simpson HDU2 w/ 5/8" Dia anchor (10" embed into footing)**

**SW3 SEISMIC IN - PLANE SHEAR**

$$h_t := 9 \text{ ft}$$

Wall height

$$L_s := L_s = 20.5 \text{ ft}$$

Total shear wall length

$$SDL_{rf} = 12 \text{ psf}$$

Dead load of roof

$$R := R_{Lup\_3\_EL} = 4.09 \text{ kip}$$

Reaction at grid

$$w_{rf} := w_{rf} = 3.665 \text{ ft}$$

Tributary width of roof on wall

$$p_{ext} = 12 \text{ psf}$$

Dead load of exterior walls

$$w_s := w_s = 4.5 \text{ ft}$$

Shear wall length

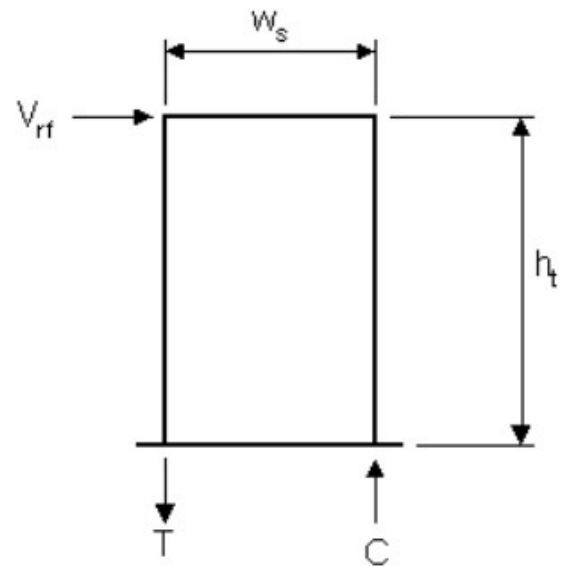

$$check_{ratio} = \text{"OK"}$$

**Aspect Ratio (Blocked Shear Wall)**

$$\frac{h_t}{w_s} = 2$$

$$check_{ratio} := \text{if } \frac{h_t}{w_s} > 3.5$$

"NG"

else

"OK"

$$(WSP) := \text{if } \frac{h_t}{w_s} < 2.0$$

Aspect ratio factor

$$(WSP) = 1$$

$$1.0$$

else

$$1.25 - 0.125 \cdot \frac{h_t}{w_s}$$

**Overtuning Forces**

$$V_{rf} := \left( R \cdot \frac{w_s}{L_s} \right) \cdot 0.7$$

Shear load at top of wall (ASD)

$$0.63 \text{ kip}$$

$$M_{ot} := V_{rf} \cdot h_t$$

Overtuning moment (ASD)

$$M_{ot} = 5.65 \text{ kip ft}$$

**Resisting Forces**

$$P_{rf} := SDL_{rf} \cdot w_{rf} \cdot w_s$$

Roof load

$$P_{rf} = 0.2 \text{ kip}$$

$$P_w := p_{ext} \cdot (2 \cdot h_t) \cdot w_s$$

Wall load

$$P_w = 0.97 \text{ kip}$$

$$M_{res} := \left( (P_{rf} + P_w) \cdot \frac{w_s}{2} \right) \cdot 0.6$$

Resisting moment (ASD)

$$M_{res} = 1.58 \text{ kip ft}$$

Plywood Shear ( ref. ANSI/AF+PA SDPWS)

$\Omega_{D_s} = 2.8$

(ref. section 4.3.3)

 $n := 1$  sides

$$w_{all} := \frac{(WSP) \cdot w_{6_8d} \cdot n}{\Omega_{D_s}} = 260.71 \text{ plf}$$

**Single Sided 7/16" Plywood/OSB w/ 8d @ 6" O.C. Panel Edges @ 12" O.C. Interior Supports (ref. table 4.3A, 15/32 values)**

$$w_v := \frac{V_{rf}}{w_s} = 139.53 \text{ plf}$$

$$check_{wv} := \text{if } \frac{w_v}{w_{all}} > 1.0 \quad \text{ratio} := \frac{w_v}{w_{all}} = 0.54$$

 $check_{wv} = \text{"OK"}$  $\text{"NG"}$ 

else

 $\text{"OK"}$ Sill Plate Anchorage  $C_D := 1.6$ 

$t_{sp} := 1.5 \text{ in}$  Sill plate thickness

$dia_a := 0.625 \text{ in}$  Anchor dia

$sp_a := 48 \text{ in}$  Anchor spacing

$Z_{11} := 930 \text{ lbf} \cdot C_D = 1.488 \text{ kip}$

Allowable load parallel to grain (ref. NDS table 12E)

$V_{sp} := w_v \cdot sp_a = 0.5581 \text{ kip}$  Shear load to each anchor

$check_a := \text{if } V_{sp} > Z_{11}$

 $\text{"NG"}$ 

else

 $\text{"OK"}$ 

$ratio_a := \frac{V_{sp}}{Z_{11}} = 0.3751$

 $check_a = \text{"OK"}$ **Use 5/8" Dia. Anchor @ 48" o.c. (6" min. embed)**Holdown

$\Omega_{HD_{ecc}} := 0.92$

HD eccentricity reduction factor (Table 4.3A, footnote 10)

$T := \frac{M_{ot} - M_{res}}{w_s} = 0.9048 \text{ kip}$

$check_T := \text{if } T > 0.25 \text{ kip}$

 $\text{"HD REQ'D"}$ 

else

 $\text{"NOT REQ'D"}$  $check_T = \text{"HD REQ'D"}$ 

$T_{all} := HDU2 \cdot \Omega_{HD_{ecc}} = 2.83 \text{ kip}$

Allowable tension load (ref. Simpson Load Tables)

$check_{HD} := \text{if } \frac{T}{T_{all}} > 1.0$

 $\text{"NG"}$ 

else

 $\text{"OK"}$  $check_{HD} = \text{"OK"}$ **Use Simpson HDU2 w/ 5/8" Dia anchor (10" embed into footing)**

SWA WIND IN - PLANE SHEAR

$$h_t := 9 \text{ ft}$$

Wall height

$$L_s := 7.75 \text{ ft} + (3.33 \text{ ft} \cdot 2 + 6 \text{ ft} \cdot 2) \cdot 50 \% \quad \text{Total shear wall length}$$

$$SDL_{rf} = 12 \text{ psf}$$

Dead load of roof

$$R := R_{Tup\_A} = 4.09 \text{ kip}$$

Reaction at grid

$$w_{rf} := \frac{24 \text{ ft} + 24 \text{ ft}}{2} + 2 \text{ ft}$$

Tributary width of roof on wall

$$p_{ext} = 12 \text{ psf}$$

Dead load of exterior walls

$$w_s := 7.75 \text{ ft}$$

Shear wall length

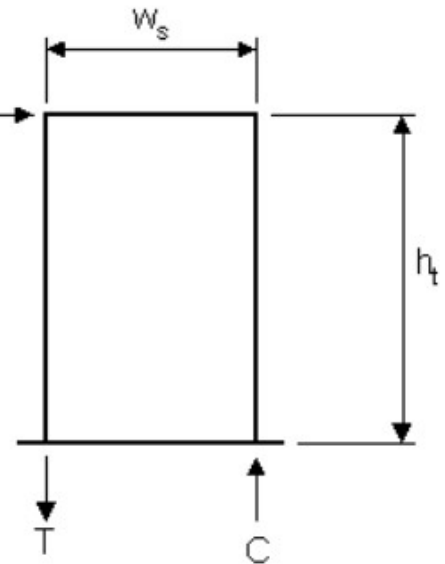

$$check_{ratio} = \text{"OK"}$$

$$\frac{h_t}{w_s} = 1.1613$$

$$check_{ratio} := \text{if } \frac{h_t}{w_s} > 3.5$$

"NG"

else

"OK"

$$(WSP) := \text{if } \frac{h_t}{w_s} < 2.0$$

Aspect ratio factor

$$(WSP) = 1$$

1.0

else

$$1.25 - 0.125 \cdot \frac{h_t}{w_s}$$

Overturning Forces

$$V_{rf} := \left( R \cdot \frac{w_s}{L_s} \right) \cdot 0.6$$

Shear load at top of wall (ASD)

$$1.11 \text{ kip}$$

$$M_{ot} := V_{rf} \cdot h_t$$

Overturning moment (ASD)

$$M_{ot} = 10.03 \text{ kip ft}$$

Resisting Forces

$$P_{rf} := SDL_{rf} \cdot w_{rf} \cdot w_s$$

Roof load

$$P_{rf} = 2.42 \text{ kip}$$

$$P_w := p_{ext} \cdot (2 \cdot h_t) \cdot w_s$$

Wall load

$$P_w = 1.67 \text{ kip}$$

$$M_{res} := \left( (P_{rf} + P_w) \cdot \frac{w_s}{2} \right) \cdot 0.6$$

Resisting moment (ASD)

$$M_{res} = 9.51 \text{ kip ft}$$

Plywood Shear ( ref. ANSI/AF+PA SDPWS)

$\Omega_{D_w} = 2.0$

(ref. section 4.3.3)

$n := 1$

sides

$$w_{all} := \frac{(WSP) \cdot w_{4\_8d} \cdot n}{\Omega_{D_w}} = 532.5 \text{ plf}$$

**Single Sided 7/16" Plywood/OSB w/ 8d @ 4" O.C. Panel Edges @ 12" O.C. Interior Supports (ref. table 4.3A, 15/32 values)**

$$w_v := \frac{V_{rf}}{w_s} = 143.77 \text{ plf}$$

$$check_{wv} := \text{if } \frac{w_v}{w_{all}} > 1.0 \text{ ratio} := \frac{w_v}{w_{all}} = 0.27$$

 $check_{wv} = \text{"OK"}$ **"NG"**

else

**"OK"**Sill Plate Anchorage

$C_D := 1.6$

$t_{sp} := 1.5 \text{ in}$  Sill plate thickness

$dia_a := 0.625 \text{ in}$  Anchor dia

$sp_a := 32 \text{ in}$

Anchor spacing

$Z_{11} := 930 \text{ lbf} \cdot C_D = 1.488 \text{ kip}$

Allowable load parallel to grain (ref. NDS table 12E)

$V_{sp} := w_v \cdot sp_a = 0.3834 \text{ kip}$  Shear load to each anchor

$check_a := \text{if } V_{sp} > Z_{11}$

**"NG"**

else

**"OK"**

$ratio_a := \frac{V_{sp}}{Z_{11}} = 0.2577$

 $check_a = \text{"OK"}$ **Use 5/8" Dia. Anchor @ 32" o.c. (6" min. embed)**Holdown

$\Omega_{HD\_ecc} := 0.92$

HD eccentricity reduction factor (Table 4.3A, footnote 10)

$T := \frac{M_{ot} - M_{res}}{w_s} = 0.0663 \text{ kip}$

$check_T := \text{if } T > 0.25 \text{ kip}$

**"HD REQ'D"**

else

**"NOT REQ'D"** $check_T = \text{"NOT REQ'D"}$ 

$T_{all} := HDU4 \cdot \Omega_{HD\_ecc} = 4.2 \text{ kip}$

Allowable tension load (ref. Simpson Load Tables)

$check_{HD} := \text{if } \frac{T}{T_{all}} > 1.0$

**"NG"**

else

**"OK"** $check_{HD} = \text{"OK"}$ **Use Simpson HDU4 w/ 5/8" Dia anchor (12" embed into footing)**

SWA SEISMIC IN - PLANE SHEAR

$$h_t := 9 \text{ ft}$$

Wall height

$$L_s := L_s = 17.08 \text{ ft}$$

Total shear wall length

$$SDL_{rf} = 12 \text{ psf}$$

Dead load of roof

$$R := R_{Tup\_A\_EL} = 4.43 \text{ kip}$$

Reaction at grid

$$w_{rf} := w_{rf} = 26 \text{ ft}$$

Tributary width of roof on wall

$$p_{ext} = 12 \text{ psf}$$

Dead load of exterior walls

$$w_s := w_s = 7.75 \text{ ft}$$

Shear wall length

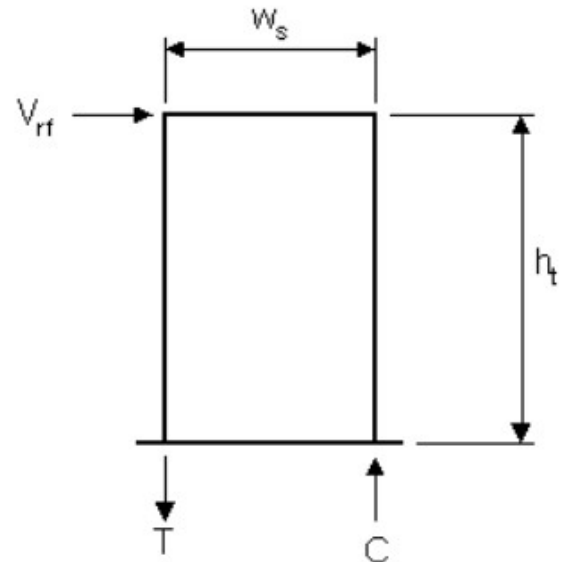
Aspect Ratio (Blocked Shear Wall)

$$\frac{h_t}{w_s} = 1.1613$$

$$check_{ratio} := \text{if } \frac{h_t}{w_s} > 3.5$$

"NG"

else

"OK"

$$check_{ratio} = \text{"OK"}$$

$$(WSP) := \text{if } \frac{h_t}{w_s} < 2.0$$

Aspect ratio factor

$$(WSP) = 1$$

1.0

else

$$1.25 - 0.125 \cdot \frac{h_t}{w_s}$$

Overtuning Forces

$$V_{rf} := \left( R \cdot \frac{w_s}{L_s} \right) \cdot 0.7$$

Shear load at top of wall (ASD)

$$1.41 \text{ kip}$$

$$M_{ot} := V_{rf} \cdot h_t$$

Overtuning moment (ASD)

$$M_{ot} = 12.66 \text{ kip ft}$$

Resisting Forces

$$P_{rf} := SDL_{rf} \cdot w_{rf} \cdot w_s$$

Roof load

$$P_{rf} = 2.42 \text{ kip}$$

$$P_w := p_{ext} \cdot (2 \cdot h_t) \cdot w_s$$

Wall load

$$P_w = 1.67 \text{ kip}$$

$$M_{res} := \left( (P_{rf} + P_w) \cdot \frac{w_s}{2} \right) \cdot 0.6$$

Resisting moment (ASD)

$$M_{res} = 9.51 \text{ kip ft}$$

Plywood Shear ( ref. ANSI/AF+PA SDPWS)

$\Omega_{D_s} = 2.8$

(ref. section 4.3.3)

$n := 1$

sides

$$w_{all} := \frac{(WSP) \cdot w_{4_8d} \cdot n}{\Omega_{D_s}} = 380.36 \text{ plf}$$

**Single Sided 7/16" Plywood/OSB w/ 8d @ 4" O.C. Panel  
Edges @ 12" O.C. Interior Supports (ref. table 4.3A, 15/32 values)**

$$w_v := \frac{V_{rf}}{w_s} = 181.54 \text{ plf}$$

$$check_{wv} := \text{if } \frac{w_v}{w_{all}} > 1.0 \text{ ratio} := \frac{w_v}{w_{all}} = 0.48$$

 $check_{wv} = \text{"OK"}$  $\text{"NG"}$  $\text{else}$  $\text{"OK"}$ Sill Plate Anchorage  $C_D := 1.6$ 

$t_{sp} := 1.5 \text{ in}$  Sill plate thickness

$dia_a := 0.625 \text{ in}$  Anchor dia

$sp_a := 32 \text{ in}$

Anchor spacing

$Z_{11} := 930 \text{ lbf} \cdot C_D = 1.488 \text{ kip}$

Allowable load parallel to grain (ref. NDS table 12E)

$V_{sp} := w_v \cdot sp_a = 0.4841 \text{ kip}$  Shear load to each anchor

$check_a := \text{if } V_{sp} > Z_{11}$

 $\text{"NG"}$  $\text{else}$  $\text{"OK"}$ 

$ratio_a := \frac{V_{sp}}{Z_{11}} = 0.3253$

 $check_a = \text{"OK"}$ **Use 5/8" Dia. Anchor @ 32" o.c. (6" min. embed)**Holdown

$\Omega_{HD_{ecc}} := 0.92$

HD eccentricity reduction factor (Table 4.3A, footnote 10)

$T := \frac{M_{ot} - M_{res}}{w_s} = 0.4063 \text{ kip}$

$check_T := \text{if } T > 0.25 \text{ kip}$

 $\text{"HD REQ'D"}$  $\text{else}$  $\text{"NOT REQ'D"}$  $check_T = \text{"HD REQ'D"}$ 

$T_{all} := HDU4 \cdot \Omega_{HD_{ecc}} = 4.2 \text{ kip}$

Allowable tension load (ref. Simpson Load Tables)

$check_{HD} := \text{if } \frac{T}{T_{all}} > 1.0$

 $\text{"NG"}$  $\text{else}$  $\text{"OK"}$  $check_{HD} = \text{"OK"}$ **Use Simpson HDU4 w/ 5/8" Dia anchor (12" embed into footing)**

SWB WIND IN - PLANE SHEAR

$$h_t := 9 \text{ ft}$$

Wall height

$$L_s := 5.25 \text{ ft} + 13.5 \text{ ft}$$

Total shear wall length

$$SDL_{rf} = 12 \text{ psf}$$

Dead load of roof

$$R := R_{Tup\_B} = 6.55 \text{ kip}$$

Reaction at grid

$$w_{rf} := \frac{24 \text{ ft} + 24 \text{ ft}}{2} + 2 \text{ ft}$$

Tributary width of roof on wall

$$p_{ext} = 12 \text{ psf}$$

Dead load of exterior walls

$$w_s := 5.25 \text{ ft}$$

Shear wall length

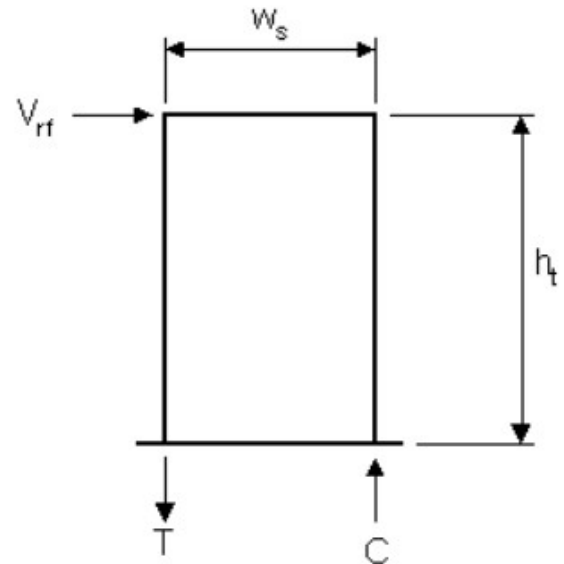

$$check_{ratio} = \text{"OK"}$$

Aspect Ratio (Blocked Shear Wall)

$$\frac{h_t}{w_s} = 1.7143$$

$$check_{ratio} := \text{if } \frac{h_t}{w_s} > 3.5$$

"NG"

else

"OK"

$$(WSP) := \text{if } \frac{h_t}{w_s} < 2.0$$

Aspect ratio factor

$$(WSP) = 1$$

1.0

else

$$1.25 - 0.125 \cdot \frac{h_t}{w_s}$$

Overtuning Forces

$$V_{rf} := \left( R \cdot \frac{w_s}{L_s} \right) \cdot 0.6$$

Shear load at top of wall (ASD)

$$1.1 \text{ kip}$$

$$M_{ot} := V_{rf} \cdot h_t$$

Overtuning moment (ASD)

$$M_{ot} = 9.9 \text{ kip ft}$$

Resisting Forces

$$P_{rf} := SDL_{rf} \cdot w_{rf} \cdot w_s$$

Roof load

$$P_{rf} = 1.64 \text{ kip}$$

$$P_w := p_{ext} \cdot (2 \cdot h_t) \cdot w_s$$

Wall load

$$P_w = 1.13 \text{ kip}$$

$$M_{res} := \left( (P_{rf} + P_w) \cdot \frac{w_s}{2} \right) \cdot 0.6$$

Resisting moment (ASD)

$$M_{res} = 4.37 \text{ kip ft}$$

Plywood Shear (ref. ANSI/AF+PA SDPWS)

$\Omega_{D_w} = 2.0$

(ref. section 4.3.3)

$n := 1$

sides

$$w_{all} := \frac{(WSP) \cdot w_{4\_8d} \cdot n}{\Omega_{D_w}} = 532.5 \text{ plf}$$

**Single Sided 7/16" Plywood/OSB w/ 8d @ 4" O.C. Panel Edges @ 12" O.C. Interior Supports (ref. table 4.3A, 15/32 values)**

$$w_v := \frac{V_{rf}}{w_s} = 209.62 \text{ plf}$$

$$check_{wv} := \text{if } \frac{w_v}{w_{all}} > 1.0 \text{ ratio} := \frac{w_v}{w_{all}} = 0.39$$

 $check_{wv} = \text{"OK"}$ **"NG"**

else

**"OK"**Sill Plate Anchorage  $C_D := 1.6$ 

$t_{sp} := 1.5 \text{ in}$  Sill plate thickness

$dia_a := 0.625 \text{ in}$  Anchor dia

$sp_a := 32 \text{ in}$

Anchor spacing

$Z_{11} := 930 \text{ lbf} \cdot C_D = 1.488 \text{ kip}$

Allowable load parallel to grain (ref. NDS table 12E)

$V_{sp} := w_v \cdot sp_a = 0.559 \text{ kip}$  Shear load to each anchor

$check_a := \text{if } V_{sp} > Z_{11}$

**"NG"**

else

**"OK"**

$ratio_a := \frac{V_{sp}}{Z_{11}} = 0.3757$

 $check_a = \text{"OK"}$ **Use 5/8" Dia. Anchor @ 32" o.c. (6" min. embed)**Holdown

$\Omega_{HD\_ecc} := 0.92$

HD eccentricity reduction factor (Table 4.3A, footnote 10)

$T := \frac{M_{ot} - M_{res}}{w_s} = 1.055 \text{ kip}$

$check_T := \text{if } T > 0.25 \text{ kip}$

**"HD REQ'D"**

else

**"NOT REQ'D"** $check_T = \text{"HD REQ'D"}$ 

$T_{all} := HDU4 \cdot \Omega_{HD\_ecc} = 4.2 \text{ kip}$

Allowable tension load (ref. Simpson Load Tables)

$check_{HD} := \text{if } \frac{T}{T_{all}} > 1.0$

**"NG"**

else

**"OK"** $check_{HD} = \text{"OK"}$ **Use Simpson HDU4 w/ 5/8" Dia anchor (12" embed into footing)**

**SWB SEISMIC IN - PLANE SHEAR**

$$h_t := 9 \text{ ft}$$

Wall height

$$L_s := L_s = 18.75 \text{ ft}$$

Total shear wall length

$$SDL_{rf} = 12 \text{ psf}$$

Dead load of roof

$$R := R_{Tup\_B\_EL} = 6.49 \text{ kip}$$

Reaction at grid

$$w_{rf} := w_{rf} = 26 \text{ ft}$$

Tributary width of roof on wall

$$p_{ext} = 12 \text{ psf}$$

Dead load of exterior walls

$$w_s := w_s = 5.25 \text{ ft}$$

Shear wall length

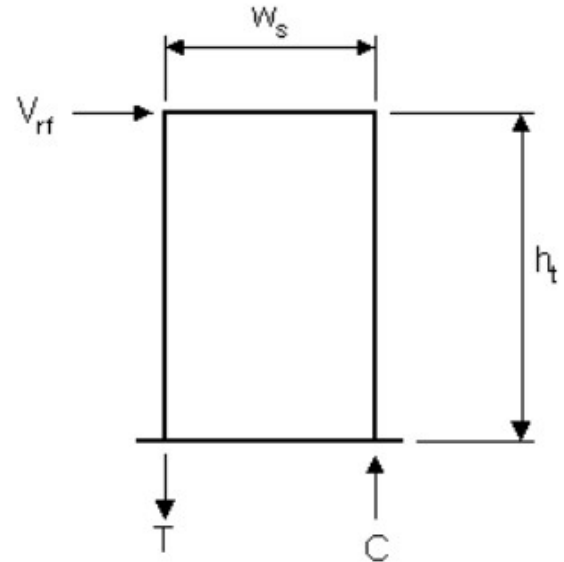
**Aspect Ratio (Blocked Shear Wall)**

$$\frac{h_t}{w_s} = 1.7143$$

$$check_{ratio} := \text{if } \frac{h_t}{w_s} > 3.5$$

$$check_{ratio} = \text{"OK"}$$

"NG"  
else  
"OK"

$$(WSP) := \text{if } \frac{h_t}{w_s} < 2.0$$

Aspect ratio factor

$$(WSP) = 1$$

1.0  
else

$$1.25 - 0.125 \cdot \frac{h_t}{w_s}$$

**Overturning Forces**

$$V_{rf} := \left( R \cdot \frac{w_s}{L_s} \right) \cdot 0.7$$

Shear load at top of wall (ASD)

$$1.27 \text{ kip}$$

$$M_{ot} := V_{rf} \cdot h_t$$

Overturning moment (ASD)

$$M_{ot} = 11.45 \text{ kip ft}$$

**Resisting Forces**

$$P_{rf} := SDL_{rf} \cdot w_{rf} \cdot w_s$$

Roof load

$$P_{rf} = 1.64 \text{ kip}$$

$$P_w := p_{ext} \cdot (2 \cdot h_t) \cdot w_s$$

Wall load

$$P_w = 1.13 \text{ kip}$$

$$M_{res} := \left( (P_{rf} + P_w) \cdot \frac{w_s}{2} \right) \cdot 0.6$$

Resisting moment (ASD)

$$M_{res} = 4.37 \text{ kip ft}$$

Plywood Shear ( ref. ANSI/AF+PA SDPWS)

$\Omega_{D_s} = 2.8$

(ref. section 4.3.3)

$n := 1$

sides

$$w_{all} := \frac{(WSP) \cdot w_{4\_8d} \cdot n}{\Omega_{D_s}} = 380.36 \text{ plf}$$

**Single Sided 7/16" Plywood/OSB w/ 8d @ 4" O.C. Panel  
Edges @ 12" O.C. Interior Supports (ref. table 4.3A, 15/32 values)**

$$w_v := \frac{V_{rf}}{w_s} = 242.29 \text{ plf}$$

$$check_{wv} := \text{if } \frac{w_v}{w_{all}} > 1.0 \text{ ratio} := \frac{w_v}{w_{all}} = 0.64$$

 $check_{wv} = \text{"OK"}$ **"NG"**

else

**"OK"**Sill Plate Anchorage  $C_D := 1.6$ 

$t_{sp} := 1.5 \text{ in}$  Sill plate thickness

$dia_a := 0.625 \text{ in}$  Anchor dia

$sp_a := 32 \text{ in}$

Anchor spacing

$Z_{ll} := 930 \text{ lbf} \cdot C_D = 1.488 \text{ kip}$

Allowable load parallel to grain (ref. NDS table 12E)

$V_{sp} := w_v \cdot sp_a = 0.6461 \text{ kip}$  Shear load to each anchor

$Check_a := \text{if } V_{sp} > Z_{ll}$

**"NG"**

else

**"OK"**

$ratio_a := \frac{V_{sp}}{Z_{ll}} = 0.4342$

 $Check_a = \text{"OK"}$ **Use 5/8" Dia. Anchor @ 32" o.c. (6" min. embed)**Holdown

$\Omega_{HD\_ecc} := 0.92$

HD eccentricity reduction factor (Table 4.3A, footnote 10)

$T := \frac{M_{ot} - M_{res}}{w_s} = 1.349 \text{ kip}$

$check_T := \text{if } T > 0.25 \text{ kip}$

**"HD REQ'D"**

else

**"NOT REQ'D"** $check_T = \text{"HD REQ'D"}$ 

$T_{all} := HDU4 \cdot \Omega_{HD\_ecc} = 4.2 \text{ kip}$

Allowable tension load (ref. Simpson Load Tables)

$check_{HD} := \text{if } \frac{T}{T_{all}} > 1.0$

**"NG"**

else

**"OK"** $check_{HD} = \text{"OK"}$ **Use Simpson HDU4 w/ 5/8" Dia anchor (12" embed into footing)**

SWC WIND IN - PLANE SHEAR

$$h_t := 9 \text{ ft}$$

Wall height

$$L_s := 10.5 \text{ ft}$$

Total shear wall length

$$SDL_{rf} = 12 \text{ psf}$$

Dead load of roof

$$R := R_{Tup\_C} = 2.46 \text{ kip}$$

Reaction at grid

$$w_{rf} := \frac{2 \text{ ft}}{2} + 2 \text{ ft}$$

Tributary width of roof on wall

$$p_{ext} = 12 \text{ psf}$$

Dead load of exterior walls

$$w_s := 10.5 \text{ ft}$$

Shear wall length

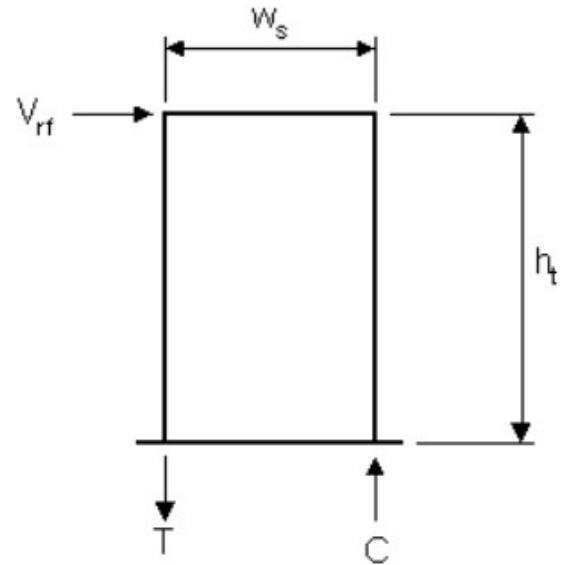

$$check_{ratio} = \text{"OK"}$$

Aspect Ratio (Blocked Shear Wall)

$$\frac{h_t}{w_s} = 0.8571$$

$$check_{ratio} := \text{if } \frac{h_t}{w_s} > 3.5$$

"NG"

else

"OK"

$$(WSP) := \text{if } \frac{h_t}{w_s} < 2.0$$

Aspect ratio factor

$$(WSP) = 1$$

1.0

else

$$1.25 - 0.125 \cdot \frac{h_t}{w_s}$$

Overturning Forces

$$V_{rf} := \left( R \cdot \frac{w_s}{L_s} \right) \cdot 0.6$$

Shear load at top of wall (ASD)

$$1.47 \text{ kip}$$

$$M_{ot} := V_{rf} \cdot h_t$$

Overturning moment (ASD)

$$M_{ot} = 13.27 \text{ kip ft}$$

Resisting Forces

$$P_{rf} := SDL_{rf} \cdot w_{rf} \cdot w_s$$

Roof load

$$P_{rf} = 0.38 \text{ kip}$$

$$P_w := p_{ext} \cdot (h_t) \cdot w_s$$

Wall load

$$P_w = 1.13 \text{ kip}$$

$$M_{res} := \left( (P_{rf} + P_w) \cdot \frac{w_s}{2} \right) \cdot 0.6$$

Resisting moment (ASD)

$$M_{res} = 4.76 \text{ kip ft}$$

Plywood Shear ( ref. ANSI/AF+PA SDPWS)

$\Omega_{D_w} = 2.0$

(ref. section 4.3.3)

$n := 1$

sides

$$w_{all} := \frac{(WSP) \cdot w_{6\_8d} \cdot n}{\Omega_{D_w}} = 365 \text{ plf}$$

**Single Sided 7/16" Plywood/OSB w/ 8d @ 6" O.C. Panel Edges @ 12" O.C. Interior Supports (ref. table 4.3A, 15/32 values)**

$$w_v := \frac{V_{rf}}{w_s} = 140.46 \text{ plf}$$

$$check_{wv} := \text{if } \frac{w_v}{w_{all}} > 1.0 \text{ ratio} := \frac{w_v}{w_{all}} = 0.38$$

 $check_{wv} = \text{"OK"}$  $\text{"NG"}$ 

else

 $\text{"OK"}$ Sill Plate Anchorage

$C_D := 1.6$

$t_{sp} := 1.5 \text{ in}$  Sill plate thickness

$dia_a := 0.625 \text{ in}$  Anchor dia

$sp_a := 48 \text{ in}$

Anchor spacing

$Z_{11} := 930 \text{ lbf} \cdot C_D = 1.488 \text{ kip}$

Allowable load parallel to grain (ref. NDS table 12E)

$V_{sp} := w_v \cdot sp_a = 0.5619 \text{ kip}$  Shear load to each anchor

$check_a := \text{if } V_{sp} > Z_{11}$

 $\text{"NG"}$ 

else

 $\text{"OK"}$ 

$ratio_a := \frac{V_{sp}}{Z_{11}} = 0.3776$

 $check_a = \text{"OK"}$ **Use 5/8" Dia. Anchor @ 48" o.c. (6" min. embed)**Holdown

$\Omega_{HD\_ecc} := 0.92$

HD eccentricity reduction factor (Table 4.3A, footnote 10)

$T := \frac{M_{ot} - M_{res}}{w_s} = 0.8106 \text{ kip}$

$check_T := \text{if } T > 0.25 \text{ kip}$

 $\text{"HD REQ'D"}$ 

else

 $\text{"NOT REQ'D"}$  $check_T = \text{"HD REQ'D"}$ 

$T_{all} := HDU2 \cdot \Omega_{HD\_ecc} = 2.83 \text{ kip}$

Allowable tension load (ref. Simpson Load Tables)

$check_{HD} := \text{if } \frac{T}{T_{all}} > 1.0$

 $\text{"NG"}$ 

else

 $\text{"OK"}$  $check_{HD} = \text{"OK"}$ **Use Simpson HDU2 w/ 5/8" Dia anchor (10" embed into footing)**

SWC SEISMIC IN - PLANE SHEAR

$$h_t := 9 \text{ ft}$$

Wall height

$$L_s := L_s = 10.5 \text{ ft}$$

Total shear wall length

$$SDL_{rf} = 12 \text{ psf}$$

Dead load of roof

$$R := R_{Tup\_C\_EL} = 2.06 \text{ kip}$$

Reaction at grid

$$w_{rf} := w_{rf} = 3 \text{ ft}$$

Tributary width of roof on wall

$$p_{ext} = 12 \text{ psf}$$

Dead load of exterior walls

$$w_s := w_s = 10.5 \text{ ft}$$

Shear wall length

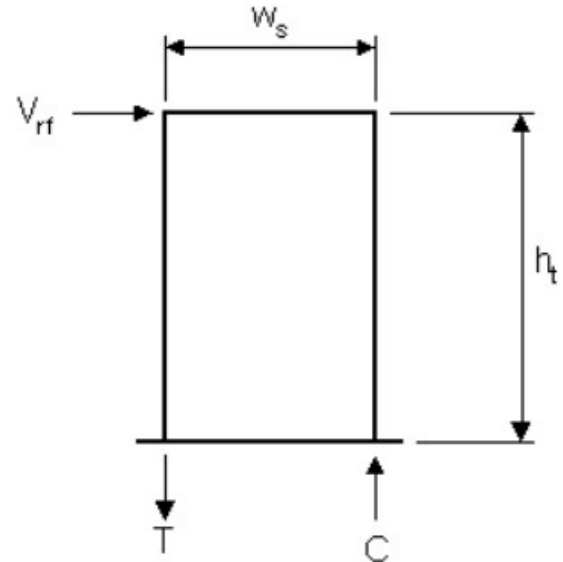

$$check_{ratio} = \text{"OK"}$$

Aspect Ratio (Blocked Shear Wall)

$$\frac{h_t}{w_s} = 0.8571$$

$$check_{ratio} := \text{if } \frac{h_t}{w_s} > 3.5$$

"NG"

else

"OK"

$$(WSP) := \text{if } \frac{h_t}{w_s} < 2.0$$

Aspect ratio factor

$$(WSP) = 1$$

$$1.0$$

else

$$1.25 - 0.125 \cdot \frac{h_t}{w_s}$$

Overtuning Forces

$$V_{rf} := \left( R \cdot \frac{w_s}{L_s} \right) \cdot 0.7$$

Shear load at top of wall (ASD)

$$1.44 \text{ kip}$$

$$M_{ot} := V_{rf} \cdot h_t$$

Overtuning moment (ASD)

$$M_{ot} = 12.98 \text{ kip ft}$$

Resisting Forces

$$P_{rf} := SDL_{rf} \cdot w_{rf} \cdot w_s$$

Roof load

$$P_{rf} = 0.38 \text{ kip}$$

$$P_w := p_{ext} \cdot (h_t) \cdot w_s$$

Wall load

$$P_w = 1.13 \text{ kip}$$

$$M_{res} := \left( (P_{rf} + P_w) \cdot \frac{w_s}{2} \right) \cdot 0.6$$

Resisting moment (ASD)

$$M_{res} = 4.76 \text{ kip ft}$$

Plywood Shear (ref. ANSI/AF+PA SDPWS)

$\Omega_{D_s} = 2.8$

(ref. section 4.3.3)

$n := 1$

sides

$$w_{all} := \frac{(WSP) \cdot w_{6\_8d} \cdot n}{\Omega_{D_s}} = 260.71 \text{ plf}$$

**Single Sided 7/16" Plywood/OSB w/ 8d @ 6" O.C. Panel Edges @ 12" O.C. Interior Supports (ref. table 4.3A, 15/32 values)**

$$w_v := \frac{V_{rf}}{w_s} = 137.36 \text{ plf}$$

$$check_{wv} := \text{if } \frac{w_v}{w_{all}} > 1.0 \text{ ratio} := \frac{w_v}{w_{all}} = 0.53$$

 $check_{wv} = \text{"OK"}$  $\text{"NG"}$ 

else

 $\text{"OK"}$ Sill Plate Anchorage  $C_D := 1.6$ 

$t_{sp} := 1.5 \text{ in}$  Sill plate thickness

$dia_a := 0.625 \text{ in}$  Anchor dia

$sp_a := 48 \text{ in}$

Anchor spacing

$Z_{11} := 930 \text{ lbf} \cdot C_D = 1.488 \text{ kip}$

Allowable load parallel to grain (ref. NDS table 12E)

$V_{sp} := w_v \cdot sp_a = 0.5494 \text{ kip}$  Shear load to each anchor

$check_a := \text{if } V_{sp} > Z_{11}$

 $\text{"NG"}$ 

else

 $\text{"OK"}$ 

$ratio_a := \frac{V_{sp}}{Z_{11}} = 0.3692$

 $check_a = \text{"OK"}$ **Use 5/8" Dia. Anchor @ 48" o.c. (6" min. embed)**Holdown

$\Omega_{HD\_ecc} := 0.92$

HD eccentricity reduction factor (Table 4.3A, footnote 10)

$T := \frac{M_{ot} - M_{res}}{w_s} = 0.7826 \text{ kip}$

$check_T := \text{if } T > 0.25 \text{ kip}$

 $\text{"HD REQ'D"}$ 

else

 $\text{"NOT REQ'D"}$  $check_T = \text{"HD REQ'D"}$ 

$T_{all} := HDU2 \cdot \Omega_{HD\_ecc} = 2.83 \text{ kip}$

Allowable tension load (ref. Simpson Load Tables)

$check_{HD} := \text{if } \frac{T}{T_{all}} > 1.0$

 $\text{"NG"}$ 

else

 $\text{"OK"}$  $check_{HD} = \text{"OK"}$ **Use Simpson HDU2 w/ 5/8" Dia anchor (10" embed into footing)**

# HDU/DTT

## Holdowns



This product is preferable to similar connectors because of (a) easier installation, (b) higher loads, (c) lower installed cost, or a combination of these features.

HDU holdowns are pre-deflected during the manufacturing process, virtually eliminating deflection under load due to material stretch. They use Strong-Drive® SDS Heavy-Duty Connector screws which install easily, reduce fastener slip and provide a greater net section when compared to bolts.

The DTT tension ties are designed for lighter-duty holddown applications on single 2x posts. The DTT1Z is installed with nails or Strong-Drive SD Connector screws and the DTT2Z installs easily with the Strong-Drive SDS Heavy-Duty Connector screws (included). The DTT1Z holdowns have been tested for use in designed shearwalls and prescriptive braced wall panels as well as prescriptive wood-deck applications (see p. 289 for deck applications).

For more information on holddown options, contact Simpson Strong-Tie.

### HDU Features:

- Uses Strong-Drive SDS Heavy-Duty Connector screws which install easily, reduce fastener slip and provide a greater net section area of the post compared to bolts
- Strong-Drive SDS Heavy-Duty Connector screws are supplied with the holdowns to ensure proper fasteners are used
- No stud bolts to countersink at openings

**Material:** See table

**Finish:** HDU — galvanized; DTT1Z and DTT2Z — ZMAX® coating; DTT2SS — stainless steel

### Installation:

- See Holddown and Tension Tie General Notes on pp. 49–50.
- The HDU requires no additional washer; the DTT requires a standard-cut washer (included with DTT2Z) be installed between the nut and the seat.
- Strong-Drive SDS Heavy-Duty Connector screws install best with a low-speed high-torque drill with a  $\frac{3}{8}$ " hex-head driver.
- Fasteners and crescent washer are included with the holdowns. For replacements, order part no. SDS25212-HDU\_ (Fill in the size needed, e.g. HDU2.)

**Codes:** See p. 12 for Code Reference Key Chart

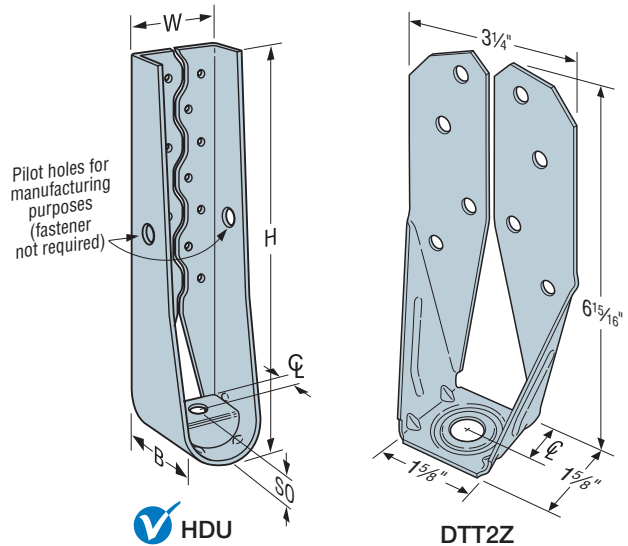

HDU

DTT2Z  
U.S. Patent  
8,555,580

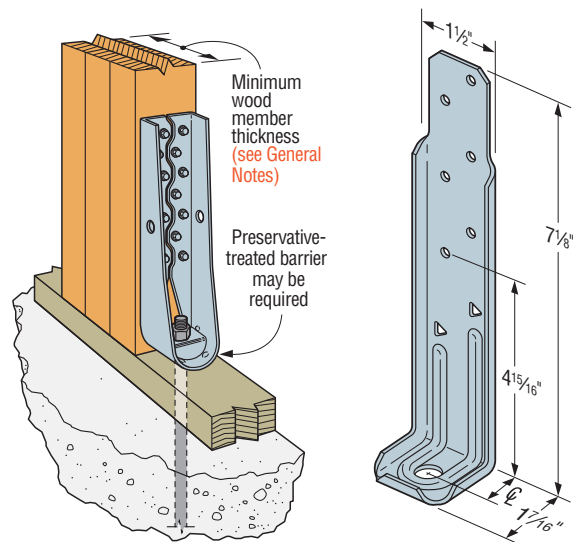

Vertical HDU  
Installation

DTT1Z  
U.S. Patent  
Pending

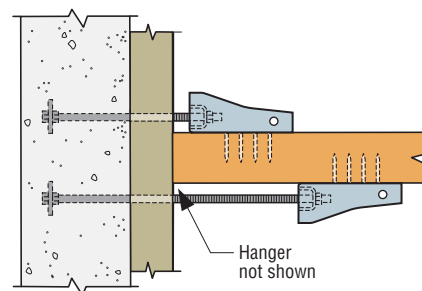

Horizontal HDU Offset Installation  
(plan view)

See Holddown and Tension Tie General Notes.

# HDU/DTT

## Holdowns (cont.)

These products are available with additional corrosion protection. For more information, see p. 15.

**SS** For stainless-steel fasteners, see p. 21.

**SD** Many of these products are approved for installation with Strong-Drive® SD Connector screws. See pp. 335-337 for more information.

Model No.	Ga.	Dimensions (in.)					Fasteners (in.)		Minimum Wood Member Size (in.)	Allowable Tension Loads (160)			Code Ref.
		W	H	B	CL	SO	Anchor Bolt Dia. (in.)	Wood Fasteners		DF/SP	SPF/HF	Deflection at Allowable Load (in.)	
DTT1Z	14	1½	7½	1¾	¾	¾	¾	(6) SD #9 x 1½	1½ x 5½	840	840	0.17	IBC, FL, LA
								(6) 0.148 x 1½		910	640	0.167	
								(8) 0.148 x 1½		910	850	0.167	
DTT2Z	14	3¼	6¼	1½	1¼	¾	½	(8) ¼ x 1½ SDS	1½ x 3½	1,825	1,800	0.105	
								(8) ¼ x 1½ SDS	3 x 3½	2,145	1,835	0.128	
DTT2Z-SDS2.5								(8) ¼ x 2½ SDS	3 x 3½	2,145	2,105	0.128	
HDU2-SDS2.5	14	3	8¼	3¼	1½	1¾	¾	(6) ¼ x 2½ SDS	3 x 3½	3,075	2,215	0.088	
HDU4-SDS2.5	14	3	10¼	3¼	1½	1¾	¾	(10) ¼ x 2½ SDS	3 x 3½	4,565	3,285	0.114	
HDU5-SDS2.5	14	3	13¾	3¼	1½	1¾	¾	(14) ¼ x 2½ SDS	3 x 3½	5,645	4,340	0.115	
HDU8-SDS2.5	10	3	16¾	3½	1¾	1½	7⁄8	(20) ¼ x 2½ SDS	3 x 3½	6,765	5,820	0.11	
									3½ x 3½	6,970	5,995	0.116	
									3½ x 4½	7,870	6,580	0.113	
HDU11-SDS2.5	10	3	22¼	3½	1¾	1½	1	(30) ¼ x 2½ SDS	3½ x 5½	9,335	8,030	0.137	
									3½ x 7¼	11,175	9,610	0.137	
HDU14-SDS2.5	7	3	25¼	3½	1¾	1¾	1	(36) ¼ x 2½ SDS	3½ x 5½	10,770	9,260	0.122	
									3½ x 7¼	14,390	12,375	0.177	
									5½ x 5½	14,445	12,425	0.172	

1. HDU14 requires heavy-hex anchor nut to achieve tabulated loads (supplied with holdown).
2. HDU14 loads on 4x6 post are applicable to installation on either the narrow or the wide face of the post.

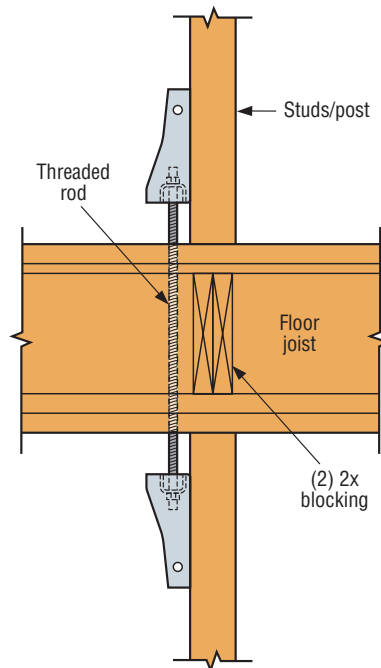

Typical HDU Tie Between Floors

## LOADING ON SOUTH HOUSE WALLS:

### NEW ROOF LOAD:

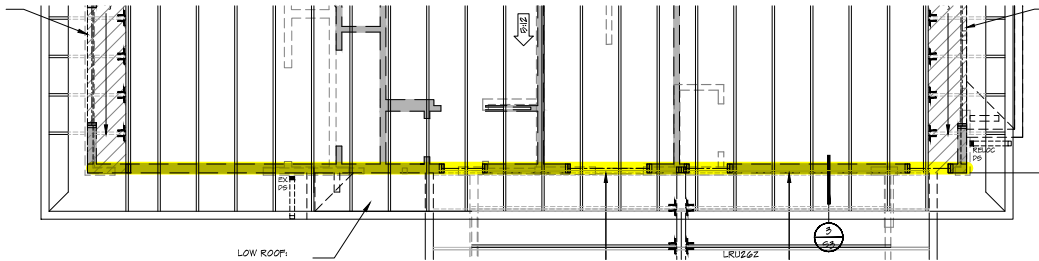

$$\text{DEAD LOAD} = 15 \text{ PSF} \times 13.5\text{ft} = 203 \text{ PLF}$$

$$\text{SNOW LOAD} = 25 \text{ PSF} \times 13.5\text{ft} = 338 \text{ PLF}$$

### NEW FLOOR LOAD:

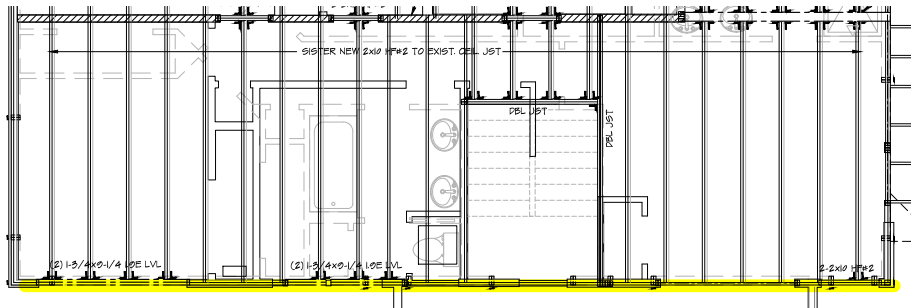

$$\text{DEAD LOAD} = 15 \text{ PSF} \times 7\text{ft} = 105 \text{ PLF}$$

$$\text{LIVE LOAD} = 40 \text{ PSF} \times 7\text{ft} = 280 \text{ PLF}$$

### EXISTING FLOOR LOAD:

$$\text{DEAD LOAD} = 15 \text{ PSF} \times 7\text{ft} = 105 \text{ PLF}$$

$$\text{LIVE LOAD} = 40 \text{ PSF} \times 7\text{ft} = 280 \text{ PLF}$$

### NEW & EXISTING WALL DEAD LOAD:

$$\text{DEAD LOAD} = 10 \text{ PSF} \times 16\text{ft} = 160 \text{ PLF}$$

### TOTAL LOADS:

$$\text{DEAD LOAD} = 203 + 105 + 105 + 160 = \mathbf{573 \text{ PLF}}$$

$$\text{LIVE LOAD} = 280 + 280 = \mathbf{560 \text{ PLF}}$$

$$\text{SNOW LOAD} = \mathbf{338 \text{ PLF}}$$

==> REQ MIN FOOTING: 1'-0" WIDE x 6" DEEP (SEE ENERCALC PRINTOUT)



PROJECT: Rankin Addition

DESCRIPTION: Loading on existing foundation

BY: NKH

DATE: 12/23/2024

JOB #: 24-123

## Wall Footing

Project File: (E) Foundation.ec6

LIC# : KW-06013860, Build:20.24.12.02

NKH Engineering

(c) ENERCALC, LLC 1982-2024

**DESCRIPTION:** Existing Foundation

### Code References

Calculations per ACI 318-19, IBC 2021

Load Combinations Used : ASCE 7-22 / IBC 2024 (L<=100psf)

### General Information

#### Material Properties

f'c : Concrete 28 day strength	=	3.0 ksi
fy : Rebar Yield	=	60.0 ksi
Ec : Concrete Elastic Modulus	=	3,122.0 ksi
Concrete Density	=	145.0 pcf
φ Values Flexure	=	0.90
Shear	=	0.750

#### Analysis Settings

Min Steel % Bending Reinf.	=	
Min Allow % Temp Reinf.	=	0.00180
Min. Overturning Safety Factor	=	1.0 : 1
Min. Sliding Safety Factor	=	1.0 : 1
AutoCalc Footing Weight as DL :	=	Yes

#### Soil Design Values

Allowable Soil Bearing	=	2.0 ksf
Increase Bearing By Footing Weight	=	Yes
Soil Passive Resistance (for Sliding)	=	250.0 pcf
Soil/Concrete Friction Coeff.	=	0.30

#### Increases based on footing Depth

Reference Depth below Surface	=	ft
Allow. Pressure Increase per foot of depth when base footing is below	=	ksf
	=	ft

#### Increases based on footing Width

Allow. Pressure Increase per foot of width when footing is wider than	=	ksf
	=	ft

#### Adjusted Allowable Bearing Pressure

= 2.073 ksf

### Dimensions

### Reinforcing

Footing Width	=	1.0 ft	Footing Thickness	=	6.0 in	Bars along X-X Axis	
Wall Thickness	=	4 in	Rebar Centerline to Edge of Concrete...			# of Bars in 12" Width	= 2
Wall center offset from center of footing	=	0 in	at Bottom of footing =		3.0 in	Reinforcing Bar Size	= # 4

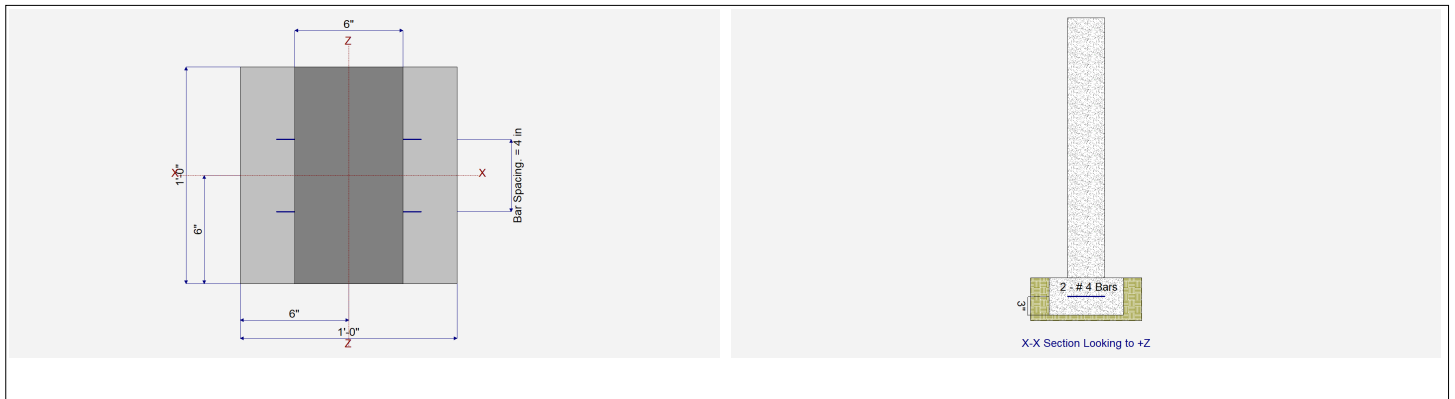

### Applied Loads

	D	Lr	L	S	W	E	H
P : Column Load	=						k
OB : Overburden	=	0.5730	0.560	0.3380			ksf
V-x	=						k
M-zz	=						k-ft
Vx applied	=		in above top of footing				

## Wall Footing

Project File: (E) Foundation.ec6

LIC#: KW-06013860, Build:20.24.12.02

NKH Engineering

(c) ENERCALC, LLC 1982-2024

**DESCRIPTION:** Existing Foundation

### DESIGN SUMMARY

**Design OK**

Factor of Safety	Item	Applied	Capacity	Governing Load Combination	
PASS	n/a	Overturing - Z-Z	0.0 k-ft	0.0 k-ft	No Overturing
PASS	n/a	Sliding - X-X	0.0 k	0.0 k	No Sliding
PASS	n/a	Uplift	0.0 k	0.0 k	No Uplift

Utilization Ratio	Item	Applied	Capacity	Governing Load Combination	
PASS	0.3174	Soil Bearing	0.6577 ksf	2.073 ksf	+D+0.750L+0.5250S
PASS	0.008250	Z Flexure (+X)	0.03873 k-ft	4.694 k-ft	+1.20D+1.60L+0.30S
PASS	0.001593	Z Flexure (-X)	0.007477 k-ft	4.694 k-ft	+1.20D+0.50L+0.150S
PASS	N/A	1-way Shear (+X)	N/A psi	73.333 psi	N/A
PASS	N/A	1-way Shear (-X)	N/A psi	73.333 psi	N/A

### Detailed Results

#### Soil Bearing

Rotation Axis & Load Combination...	Gross Allowable	Xecc	Actual Soil Bearing Stress		Actual / Allowable Ratio
			-X	+X	
D Only	2.073 ksf	0.0 in	0.3590 ksf	0.3590 ksf	0.173
+D+L	2.073 ksf	0.0 in	0.6390 ksf	0.6390 ksf	0.308
+D+0.70S	2.073 ksf	0.0 in	0.4773 ksf	0.4773 ksf	0.230
+D+0.750L	2.073 ksf	0.0 in	0.5690 ksf	0.5690 ksf	0.275
+D+0.750L+0.5250S	2.073 ksf	0.0 in	0.6577 ksf	0.6577 ksf	0.317
+0.60D	2.073 ksf	0.0 in	0.2154 ksf	0.2154 ksf	0.104
+D+0.750L+0.10S	2.073 ksf	0.0 in	0.5859 ksf	0.5859 ksf	0.283

Units : k-ft

#### Overturing Stability

Rotation Axis & Load Combination...	Overturing Moment	Resisting Moment	Stability Ratio	Status
Footing Has NO Overturing				

#### Sliding Stability

Force Application Axis Load Combination...	Sliding Force	Resisting Force	Sliding SafetyRatio	Status
Footing Has NO Sliding				

#### Footing Flexure

Flexure Axis & Load Combination	Mu k-ft	Which Side ?	Tension @ Bot. or Top ?	As Req'd in^2	Gvrn. As in^2	Actual As in^2	Phi*Mn k-ft	Status
+1.40D	0.009363	-X	Top	0.1296	Min Temp %	0.4	4.694	OK
+1.40D	0.009363	+X	Top	0.1296	Min Temp %	0.4	4.694	OK
+1.20D+1.60L	0.03398	-X	Bottom	0.1296	Min Temp %	0.4	4.694	OK
+1.20D+1.60L	0.03398	+X	Bottom	0.1296	Min Temp %	0.4	4.694	OK
+1.20D+1.60L+0.30S	0.03873	-X	Bottom	0.1296	Min Temp %	0.4	4.694	OK
+1.20D+1.60L+0.30S	0.03873	+X	Bottom	0.1296	Min Temp %	0.4	4.694	OK
+1.20D+0.50L	0.0051	-X	Bottom	0.1296	Min Temp %	0.4	4.694	OK
+1.20D+0.50L	0.0051	+X	Bottom	0.1296	Min Temp %	0.4	4.694	OK
+1.20D	0.008025	-X	Top	0.1296	Min Temp %	0.4	4.694	OK
+1.20D	0.008025	+X	Top	0.1296	Min Temp %	0.4	4.694	OK
+1.20D+0.50L+S	0.02094	-X	Bottom	0.1296	Min Temp %	0.4	4.694	OK
+1.20D+0.50L+S	0.02094	+X	Bottom	0.1296	Min Temp %	0.4	4.694	OK
+1.20D+S	0.007819	-X	Bottom	0.1296	Min Temp %	0.4	4.694	OK
+1.20D+S	0.007819	+X	Bottom	0.1296	Min Temp %	0.4	4.694	OK
+1.20D+0.50L+0.30S	0.009853	-X	Bottom	0.1296	Min Temp %	0.4	4.694	OK
+1.20D+0.50L+0.30S	0.009853	+X	Bottom	0.1296	Min Temp %	0.4	4.694	OK
+0.90D	0.006019	-X	Top	0.1296	Min Temp %	0.4	4.694	OK
+0.90D	0.006019	+X	Top	0.1296	Min Temp %	0.4	4.694	OK
+1.20D+0.50L+0.150S	0.007477	-X	Bottom	0.1296	Min Temp %	0.4	4.694	OK
+1.20D+0.50L+0.150S	0.007477	+X	Bottom	0.1296	Min Temp %	0.4	4.694	OK

Units : k

#### One Way Shear

Load Combination...	vu @ -X	vu @ +X	vu:Max	Φ vn	vu / Φ vn	Status
+1.40D	0.0 psi	0.0 psi	0.0 psi	73.3 psi	0.000	OK
+1.20D+1.60L	0.0 psi	0.0 psi	0.0 psi	73.3 psi	0.000	OK

Project Title: Rankin Addition  
 Engineer: NKH  
 Project ID: 24-123  
 Project Descr:

**Wall Footing**

Project File: (E) Foundation.ec6

LIC# : KW-06013860, Build:20.24.12.02

NKH Engineering

(c) ENERCALC, LLC 1982-2024

**DESCRIPTION:** Existing Foundation

**One Way Shear**

Units : k

Load Combination...	vu @ -X	vu @ +X	vu:Max	$\phi$ vn	vu / $\phi$ vn	Status
+1.20D+1.60L+0.30S	0.0 psi	0.0 psi	0.0 psi	73.3 psi	0.000	OK
+1.20D+0.50L	0.0 psi	0.0 psi	0.0 psi	73.3 psi	0.000	OK
+1.20D	0.0 psi	0.0 psi	0.0 psi	73.3 psi	0.000	OK
+1.20D+0.50L+S	0.0 psi	0.0 psi	0.0 psi	73.3 psi	0.000	OK
+1.20D+S	0.0 psi	0.0 psi	0.0 psi	73.3 psi	0.000	OK
+1.20D+0.50L+0.30S	0.0 psi	0.0 psi	0.0 psi	73.3 psi	0.000	OK
+0.90D	0.0 psi	0.0 psi	0.0 psi	73.3 psi	0.000	OK
+1.20D+0.50L+0.150S	0.0 psi	0.0 psi	0.0 psi	73.3 psi	0.000	OK